

2024 catalog

For CO₂ and fiber laser consumables
Replacement parts suitable for Mazak[®]

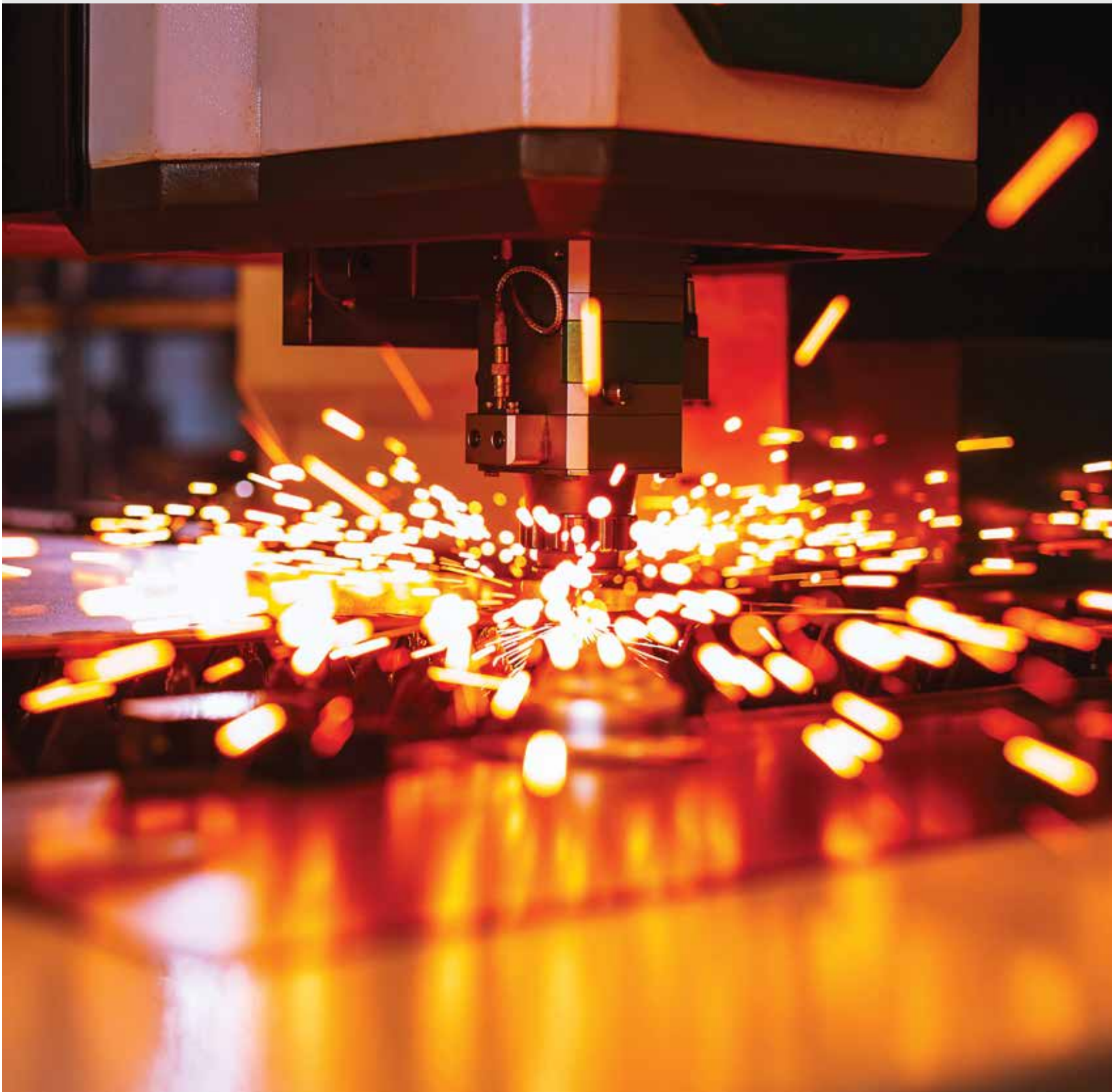

Centricut delivers

- OEM quality nozzles, ceramics and optics
- Technical and application support from our OEM-trained technicians
- 100% satisfaction guarantee



CO₂ and fiber laser nozzles

Nozzle options

All Centricut nozzles are engineered and manufactured to the highest standards. Select the OEM quality nozzle best suited for your application needs

Copper

Most commonly used nozzle offering good durability and nozzle life. Primary nozzle type for fiber lasers.

Chrome plated

Shiny, mirror-like finish provides increased spatter resistance, improved durability and longer life than copper nozzles. Not recommended for use on fiber lasers.

Look for CP in the part number to identify a chrome plated nozzle

Hard chrome plated

Premium nozzles offering the highest level of durability and longest nozzle life. These nozzles are not as shiny as chrome plated and have a dull appearance. Not recommended for use on fiber lasers.

Look for HCP in the part number to identify a hard chrome nozzle.

CP (chrome plated)	Nozzles plated with chrome for increased durability. These nozzles are easier to clean, resist damage due to 'tip-ups' and have better spatter resistance over non-plated nozzles. For use in all laser cutting applications.
Conical	Conical internal geometry for high pressure, non-ferrous cutting applications using nitrogen, air or argon.
Cylindrical	Cylindrical internal geometry for low pressure, mild steel cutting applications using oxygen.
Double	Insert pressed into a standard cylindrical nozzle for improved edge quality, laminar gas flow and spatter resistance. Primarily used in mild steel applications.
HCP (hard chrome plated)	Enhanced durability chrome plated nozzles. These nozzles are easier to clean, resist damage due to 'tip-ups' and have better spatter resistance over non-plated nozzles. For use in all laser cutting applications.
HP (high pressure) HD (high density)	Conical style nozzle for high pressure, non-ferrous cutting applications using nitrogen, air or argon.
Inner	Also referred to as a 'nozzle insert'. Works in conjunction with an outer nozzle to create a double nozzle. Primarily used in mild steel applications.
Low pressure	Cylindrical style nozzle for low pressure, mild steel cutting applications using oxygen.
Outer	Works in conjunction with an inner nozzle to create a double nozzle. Primarily used in mild steel applications.
Shower	Nozzles with a center orifice surrounded by smaller jets. The smaller jets focus the assist gas into the kerf, creating improved edge quality and the ability to cut thicker material. Primarily used in mild steel applications.

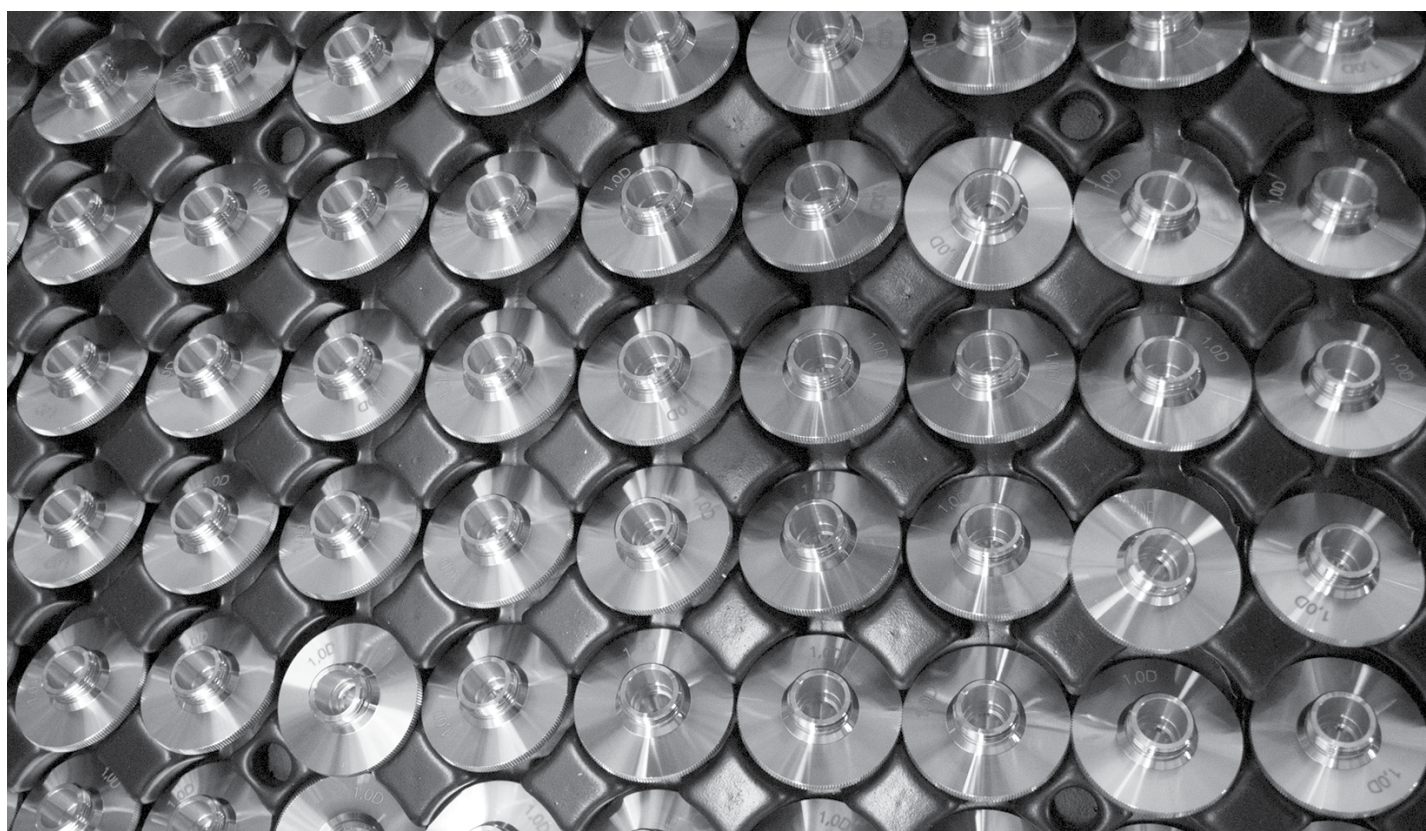

CO₂ and fiber laser optics

Optics key

Lens	
MEN	Meniscus
PLX	Plano-convex
MTD	Mounted
Not MTD	Not mounted
PO	Plano
MP5 or ULA	Ultra low absorption
AR	Anti-reflection
ZNSE	Zinc selenide
FS	Fused silica
DIA	Diameter
FL	Focal length
ET	Edge thickness
WD	Working distance

How to handle optics

Follow these easy steps, when cleaning or changing your optic, to help maximize the life and performance of your lens

- Avoid touching coated surfaces of the lens and hold the optic by its sides
- Wear powder-free finger cots or latex gloves when handling
- Do not use any tools or sharp objects when handling the optic or when removing it from its packaging
- Ensure the work surface is clean and free of oils, grease and dirt
- Do not place the optic on hard surfaces as they scratch easily
- Once the optic has been unpacked, carefully place it on the lens tissue in which it was originally wrapped

Optics disposal

It is important to dispose of used laser optics at a licensed industrial waste facility which is in compliance with all local, state, and federal regulations. If you don't have access to a licensed industrial waste facility, and purchased your laser optics through Centricut, you may return them to Centricut for proper disposal. This service is only available to Centricut customers.

All optics returned to Centricut must:

- Include return authorization and invoice numbers
- Be sealed in a plastic bag to minimize any hazards
- Remove excess ZnSe powder prior to sealing

*Acceptance of goods will be refused if not packaged correctly or if the return authorization number isn't included



Centricut part number	Reference number	Type	Material	Diameter	Focal length	Edge thickness
Fiber laser lens						
NT375-7955		PLX	FS	30 mm	123 mm	3.82 mm
TR300-9799	1869799	PLX	FS	30 mm	146 mm	8.0 mm
TR300-3107	1603107	PLX	FS	40 mm	150 mm	8.0 mm
AM313-0238	7710238, 71565737	PLX	FS	50.8 mm	190 mm	11.4 mm
SA384-0022	316-301-0022, 970128	PLX	FS	25.4 mm	200 mm	6.35 mm
SA384-0026	316-301-0026, ESTFL02119	PLX	FS	38.1 mm	210 mm	6.35 mm
PR361-8988NM	968988, 344631	PLX	FS	1.5"	5.0"	.280"
MB312-8858		PLX	FS	2.0"	7.5"	.45"
PR361-0773	970773/M15-15-B X-SP-7MM	PLX MTD	FS	1.5"	5.0"	.275"
PR361-8988	LH968988PVL, 576.41.005	PLX MTD	FS	1.5"	5.0"	.280"

Centricut part number	Reference number	Material	Diameter	Edge thickness
Fiber laser windows				
PT317-1424	P0588-1022-00001	FS	21.5 mm	2.0 mm
PT317-0589	970397, 6930003260, P0589-360-00002, R26RT006410, R26ZC90110	FS	22.35 mm	4.0 mm
PT317-9360	6930003260, P0589-360-00001	FS	22.35 mm	4.0 mm
MB312-2336	632336-117	FS	25.4 mm	4.0 mm
RT300-0035	211LCG0035, 211LCG0037	FS	27.9 mm	4.1 mm
PT317-0010	P0253-1034-00001	FS	30.0 mm	1.5 mm
TR300-6719	766719, P0795-1201-00002	FS	30.0 mm	5.0 mm
SA384-0007	316-304-0007, ESTFL001407, 632755-117	FS	32.0 mm	6.35 mm
BY314-5979	10086368, 10071591, 5335979	Sapphire	34.0 mm	2.8 mm
TR300-4767	1614767	FS	34.0 mm	4.9 mm
PR361-0089	1057.81000.089	FS	35.0 mm	1.5 mm
BY314-5746	968752, 10045746, 10-02-01-5511	QTZ	36.0 mm	5.0 mm
PR361-0474	970474	FS	37.0 mm	4.0 mm
PT317-1551	P0595-61551, P0595-58601-61551	FS	37.0 mm	7.0 mm
PT317-1425	SCR-01	FS	38.0 mm	5.2 mm
CN307-3987	913987, 71598028	FS	38.1 mm	1.6 mm
MZ315-6850	Z50ZZ016850	FS	42.0 mm	9.0 mm
MZ315-5350	Z50SA015350, W495	FS	42.0 mm	9.0 mm
AM313-1308	71571308, 5172635	FS	45.0 mm	3.0 mm
PT317-5919	77005919	FS	48.0 mm	7.0 mm
PT317-1789	284.0402, 971789, 717062	FS	50.0 mm	3.18 mm
MB312-0137	633744-137	FS	50.0 mm	8.0 mm
AM313-0026	71570026	FS	OCTAGONAL	1.5 mm

Centricut is not affiliated with the named manufacturers. Reference to machines, parts, descriptions, and model numbers are for convenience in verifying compatibility only. All parts are made by or for Centricut and are not made by the referenced manufacturers (unless expressly indicated). Centricut is a registered trademark of Hypertherm, Inc. All other trademarks are the properties of their respective owners.

Centricut part number	Reference number	Type	Material	Diameter	Focal length	Edge thickness
CO ₂ lenses						
TR300-0115 (Cut - No RFID)		MEN	ZNSE	1.969"	4.528"	.350"
TR300-0130 (Cut - No RFID)	400130LMA , 0380117, D40 Cut, 630790-117	MEN	ZNSE	1.575"	5.118"	.295"
TR300-8123	518123	MEN	ZNSE	1.575"	6.102"	.295"
TR300-0175 (Cut - No RFID)	1330448, 62440	MEN	ZNSE	1.969"	6.89"	.350"
TR300-0250 (Cut - No RFID)	400250LMA, 0380115, D40 Cut, 630789-117	MEN	ZNSE	1.575"	9.842"	.295"
TR300-2500 (Cut - No RFID)	1330443, 62439	MEN	ZNSE	1.969"	9.842"	.350"
LL342-1819	166634, 61819	MEN	ZNSE	1.1"	5.0"	.236"
TR300-0163	350163, 861143, LMZ1.5-0.29-10.00-2048	MEN	ZNSE	1.5"	10.0"	.290"
TR300-6477	726477	MEN	ZNSE	1.5"	10.0"	.354"
BY314-0185	4-00185, 4-00372, 142375, 60603	MEN	ZNSE	1.5"	3.75"	.236"
TR300-6104	346104, 61962, 831393	MEN	ZNSE	1.5"	3.75"	.290"
BY314-0736	414323, 4-10736	MEN	ZNSE	1.5"	3.75"	.354"
BY314-0186	60260, 507790, 4-00186, 110111	MEN	ZNSE	1.5"	5.0"	.236"
TR300-8114	088114, 60696, 406294, 110109, 61014, 658108, 29100023, 6930001002	MEN	ZNSE	1.5"	5.0"	.290"
BY314-5094	767963, 60615, 4-05094, 110113, 358186, 62710	MEN	ZNSE	1.5"	5.0"	.354"
PR361-0004	62709, 621644, 120216	MEN	ZNSE	1.5"	5.0"	.354"
PT317-0001	61851, 312370	MEN	ZNSE	1.5"	7.5"	.125"
BY314-0187	784964, 60602, 4-00187, 110112	MEN	ZNSE	1.5"	7.5"	.236"
TR300-7517	097517, 60697, 702232, 110110, 61983	MEN	ZNSE	1.5"	7.5"	.290"
LL342-1171	61171	MEN	ZNSE	1.5"	7.5"	.310"
BY314-5095	60616, 4-05095, 570721, 110114, 361129	MEN	ZNSE	1.5"	7.5"	.354"
BY314-8637	698637	MEN	ZNSE	1.5"	7.5"	.354"
TR300-1972	61961, 141972, 977976	MEN	ZNSE	1.5"	8.85"	.290"
TR300-8123	518123	MEN	ZNSE	1.575"	6.102"	.295"
LV333-0176	480176, 29100115	MEN	ZNSE	1.75"	5.0"	.354"
LV333-1551	981551, LMZ2.0-0.380-10.0-2053, 29100061S	MEN	ZNSE	2.0"	10.0"	.380"
PT317-6326	206326	MEN	ZNSE	2.0"	5.0"	.378"
LV333-1004	458138, LMZ2.0-0.380-5.00-2051, PLLMZ0024, 29100154	MEN	ZNSE	2.0"	5.0"	.380"
CN307-2376	61405, 695399, 922376, 60698, 29100055	MEN	ZNSE	2.0"	7.5"	.380"
AM313-0305	61161, 81140305, LPCZ-1.10-0.16-5.0-1044, PLLPZ0132, 561067	PLX	ZNSE	1.1"	5.0"	.160"
AM313-6602	726602	PLX	ZNSE	1.1"	7.5"	.160"
AM313-0657	600657, 71502030, LPCZ-1.5-0.30-10.0-1128	PLX	ZNSE	1.5"	10.0"	.300"
TK374-2235	312235	PLX	ZNSE	1.5"	12.5"	.300"
PT317-8950	148950	PLX	ZNSE	1.5"	2.5"	.085"
MZ315-0130	60830, Z50MB000130, 962834, 766479	PLX	ZNSE	1.5"	5.0"	.118"
TR300-0002	61163, LMZ1.5-0.16-5.00-2043, 706491, 907557, PLCZ-1.5-0.16-5.0-1116	PLX	ZNSE	1.5"	5.0"	.160"
MZ315-0160	60770, 227092, Z50MB000130H, LPCZ-1.5-0.236-5.0-1122, 834-319-002	PLX	ZNSE	1.5"	5.0"	.236"
PR361-9011	834-319-011, 60905, 658108, ZC15500300, Z50MB000400, 578662, MLL00016	PLX	ZNSE	1.5"	5.0"	.300"
MB312-500	W500, 60905, 110144, LPCZ-1.5-0.30-5.0-1125, PLLPZ0132	PLX	ZNSE	1.5"	5.0"	.310"
CN307-8085	941031, 61001, 908085, ZC15513280, 110092, PLLPZ0033	PLX	ZNSE	1.5"	5.0"WD	.280"
PR361-0003	60784, LPCZ-1.5-0.236-7.5-1123	PLX	ZNSE	1.5"	7.5"	.236"
PR361-9012	834-319-012, 60906, 618938, 306068, 741363, 60882, 299133, 71501070NM, 62649	PLX	ZNSE	1.5"	7.5"	.300"
MB312-018	60906, W018, 383862, 60906LA, W018, 62649ULA, 383862, 62649LA	PLX	ZNSE	1.5"	7.5"	.310"
CN307-9484	909484, 61002, 464497, 100096, LPCZ-1.5-0.280-5.13-1007, PLLPZ0052	PLX	ZNSE	1.5"	7.5"WD	.280"
PT317-8275	628275, W502A, 630736-117	PLX	ZNSE	2.0"	10.0"	.310"
PT317-0537	960537	PLX	ZNSE	2.0"	10.0"	.380"
CN307-4498	154498, 926274	PLX	ZNSE	2.0"	10.0"WD	.380"
TK374-7338	197338	PLX	ZNSE	2.0"	11.25"	.310"
MZ315-5980	145980	PLX	ZNSE	2.0"	5.0"	.300"
MB312-505	W505, 110169, PLLPZ0162, 304725, 61003, Z50ZZ005160	PLX	ZNSE	2.0"	5.0"	.310"
MZ315-0516A	61019, Z50ZZ00516A, Z50ZZ013480, 81140307, 741363	PLX	ZNSE	2.0"	5.0"	.380"

Centricut is not affiliated with the named manufacturers. Reference to machines, parts, descriptions, and model numbers are for convenience in verifying compatibility only. All parts are made by or for Centricut and are not made by the referenced manufacturers (unless expressly indicated). Centricut is a registered trademark of Hypertherm, Inc. All other trademarks are the properties of their respective owners.

Centricut part number	Reference number	Type	Material	Diameter	Focal length	Edge thickness
CO ₂ lenses (continued)						
MZ315-3480HA	158039, Z50ZZ013480 HIGH ACCURACY	PLX	ZNSE	2.0"	5.0"	.380"
CN307-0676	870676, 61514, LPCZ-2.0-0.38-5.19-1141, PLLPZ0116	PLX	ZNSE	2.0"	5.0"WD	.380"
MZ315-3470HA	769062, Z50ZZ013470 HIGH ACCURACY	PLX	ZNSE	2.0"	7.5"	.380"
NT375-4494	634494, LPCZ-2.0-0.30-7.5-1133	PLX	ZNSE	2.0"	7.5"	.300"
MB312-510	W510, 61004, 892020, 110122, PLLPZ0138	PLX	ZNSE	2.0"	7.5"	.310"
MZ315-0520A	61405, 232771, Z50ZZ00520A, MLL00018, Z50ZZ005200, Z50ZZ013470, 81140186	PLX	ZNSE	2.0"	7.5"	.380"
CN307-1603	61515, 781603, LPCZ-2.0-0.38-7.67-1143, PLLPZ0115	PLX	ZNSE	2.0"	7.5" WD	.380"
TK374-3478	541344, 263478, Z50ZZ00530A, LPCZ-2.0-0.31-7.45-1137	PLX	ZNSE	2.0"	8.75"	.310"
TK374-6670	236670, 61690, Z50ZZ00550A	PLX	ZNSE	2.5"	10.0"	.390"
TK374-1592	178937	PLX	ZNSE	2.5"	11.25"	.310"
TK374-8593	828593	PLX	ZNSE	2.5"	12.5"	.390"
TK374-3827	243827, Z50ZZ00540A, LPCZ-2.5-0.31-8.75-1145	PLX	ZNSE	2.5"	8.75"	.310"
AM313-0221	81140221, 6067639	PLX MTD	ZNSE	1.5"	3.75"	.300"
AM313-0306	81140306, 65024, 578662/M16-15-1C-P5.0, PLLPZ0133, 6874793	PLX MTD	ZNSE	1.5"	5.0"	.300"
AM313-1216	578662/M20-15-1C-P5.0, 9001216A, 71501072, 7973109, 6360374	PLX MTD	ZNSE	1.5"	5.0"	.300"
AM313-8662	578662/M21-15-1C-P5.0, 6060415	PLX MTD	ZNSE	1.5"	5.0"	.300"
AM313-9830	65101, 578662, 6547252	PLX MTD	ZNSE	1.5"	5.0"	.300"
AM313-1215	9001215A, 306068/M21-15-1C-P7.5, 7973110, 71501070, 6395647	PLX MTD	ZNSE	1.5"	7.5"	.300"
AM313-9831	71369831, 65102, 6550214	PLX MTD	ZNSE	1.5"	7.5"	.300"
AM313-10F1	680154-001, 71710061, 6021844	PLX MTD	ZNSE	2.0"	10.0"	.380"
AM313-0307	65035, 81140307, 741363, 6068456	PLX MTD	ZNSE	2.0"	5.0"	.380"
AM313-50F1	71710059, 741363M30-20-1C-P5.0, 6296946	PLX MTD	ZNSE	2.0"	5.0"	.380"
AM313-0400	306068, 65025, 81140400, 6022704	PLX MTD	ZNSE	2.0"	7.5"	.300"
AM313-0186	65038, 81140186, PLLPZ0156, 6068413	PLX MTD	ZNSE	2.0"	7.5"	.380"
AM313-75F1	232771M31-20-1C-P7.5, 71710030, 6243925	PLX MTD	ZNSE	2.0"	7.5"	.380"
BY314-7014MP5	460386, 4-07014	MEN	ZNSE MP5	1.5"	10.0"	.354"
BY314-0186MP5	4-00186, 528717, 60260LA	MEN	ZNSE MP5	1.5"	5.0"	.236"
TR300-8114MP5	60696LA, 312503, 29100023, 88114, PLLPZ0125B	MEN	ZNSE MP5	1.5"	5.0"	.290"
BY314-5094MP5	123397, 4-07475, 60615LA, LMZ1.5-0.354-5.0-2008	MEN	ZNSE MP5	1.5"	5.0"	.354"
BY314-0187MP5	714512, 60602LA, 4-00187	MEN	ZNSE MP5	1.5"	7.5"	.236"
TR300-7517MP5	60697LA, 97517, 474644, PLLPZ0126B	MEN	ZNSE MP5	1.5"	7.5"	.290"
BY314-5095MP5	602033, 60616LA, 4-07476, LMZ1.5-0.354-7.5-2009, PLLPZ0130B, 62710	MEN	ZNSE MP5	1.5"	7.5"	.354"
BY314-8294MP5	996707, 10048294	MEN	ZNSE MP5	1.5"	9.0"	.354"
HW405-4913	114913	MEN	ZNSE MP5	2.0"	10.0"	.379"
HW405-5270	355270	MEN	ZNSE MP5	2.0"	5.0"	.378"
HW405-7143	527143, 467572, 60698LA, 291005-5, 308332, PLLMZ0025B	MEN	ZNSE MP5	2.0"	7.5"	.379"
MZ315-0160MP5	60770LA, 857048, Z50MB000160	PLX	ZNSE MP5	1.5"	5.0"	.236"
MZ315-0400MP5	106106, PLLPZ0132B, 60905LA, Z50MB000400, 62670ULA	PLX	ZNSE MP5	1.5"	5.0"	.300"
CN307-8085MP5	61001LA, 794914, 908085,	PLX	ZNSE MP5	1.5"	5.0"WD	.280"
MB312-018MP5	383862	PLX	ZNSE MP5	1.5"	7.5"	.300"
CN307-9484MP5	PLLPZ0052B	PLX	ZNSE MP5	1.5"	7.5"WD	.315"
MB312-505MP5	61003LA, 922203, W505	PLX	ZNSE MP5	2.0"	5.0"	.310"
AM313-0307NMP5	81140307, 61019LA, 753010	PLX	ZNSE MP5	2.0"	5.0"	.380"
CN307-0211MP5	540211, 61019LA, 922377	PLX	ZNSE MP5	2.0"	5.0"WD	.380"
MB312-510MP5	61004LA, 635061, W510,	PLX	ZNSE MP5	2.0"	7.5"	.310"
CN307-2376MP5	329011, 922376, 61515ULA,	PLX	ZNSE MP5	2.0"	7.5"	.380"
MZ315-0520AMP5	392125, 61405LA, Z50ZZ000520A, PLLPZ0135B, 81140186 61405ULA	PLX	ZNSE MP5	2.0"	7.5"	.380"

Centricut is not affiliated with the named manufacturers. Reference to machines, parts, descriptions, and model numbers are for convenience in verifying compatibility only. All parts are made by or for Centricut and are not made by the referenced manufacturers (unless expressly indicated). Centricut is a registered trademark of Hypertherm, Inc. All other trademarks are the properties of their respective owners.

Centricut part number	Reference number	Type	Material	Diameter	Focal length	Edge thickness
CO ₂ lenses (continued)						
AM313-0306MP5	65024LA, 81140306, 106106, M16-15-1C-P5.0, 6936448	PLX MTD	ZNSE MP5	1.5"	5.0"	.300"
AM313-1216MP5	106106, M20-15-1C-P5.0, 6071896	PLX MTD	ZNSE MP5	1.5"	5.0"	.300"
AM313-9830MP5	71369830, 106106, 65101LA, 106106/M16-15-1C-P5.0-A2-NI-1A	PLX MTD	ZNSE MP5	1.5"	5.0"	.300"
AM313-0400MP5	65025LA, 383862/M16-15-1C-P7.5-A2-NI-1A, 81140400, 383862	PLX MTD	ZNSE MP5	1.5"	7.5"	.300"
AM313-1215MP5	M21-15-1C-P7.5, 383862, 6071853	PLX MTD	ZNSE MP5	1.5"	7.5"	.300"
AM313-9831MP5	65102LA, 71369831, 383862	PLX MTD	ZNSE MP5	1.5"	7.5"	.300"
AM313-0307MP5	81140307, M16-20-1C-P5.0, 753010, 65035LA, 753010M16-20-1C-P5.0	PLX MTD	ZNSE MP5	2.0"	5.0"	.380"
AM313-0186MP5	392125, 65038LA, M16-20-1C-P7.5, 81140186, 6816292	PLX MTD	ZNSE MP5	2.0"	7.5"	.380"

Accessories

Centricut part number	Reference number	Description	Pkg qty
TR300-6452		Lens cleaning Tiffen paper (50 pcs)	1
TR300-1115		Lens cleaning pre-cut cotton (100 pcs)	1
TR300-1010		Dropper, lens cleaning fluid	1
TR300-1112		Optical cleaning fluid	1
TR300-0699	70675699 REVA	Lens cleaning swabs (25 pcs)	1
TR300-7991	27991	Polyester wipes 4" x 4" (100 pcs)	1
TR301-0282		Injector	1
TR300-LSA		Lens stress analyzer	1
TR300-255		Magnifying loop	1
TR300-271		Base, mirror maintenance	1
TR300-7388	787388	Mirror polish .1UM 250ML	1
MZ335-115	AL1115/M	MZ-Wire, Indium .8 mm x 125 mm 1.5" Lens	1
MZ335-120	AL1120/M	MZ-Wire, Indium .8 mm x 160 mm 2.0" Lens	1

Centricut is not affiliated with the named manufacturers. Reference to machines, parts, descriptions, and model numbers are for convenience in verifying compatibility only. All parts are made by or for Centricut and are not made by the referenced manufacturers (unless expressly indicated). Centricut is a registered trademark of Hypertherm, Inc. All other trademarks are the properties of their respective owners.

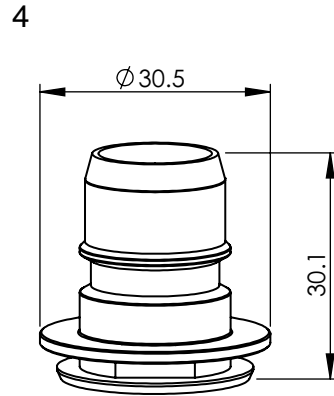
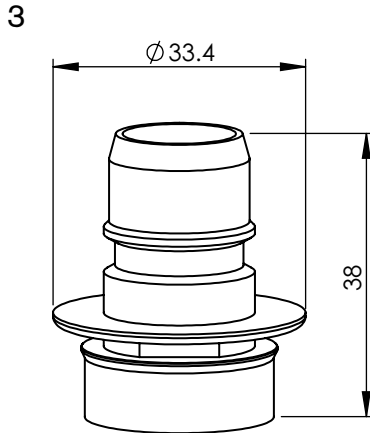
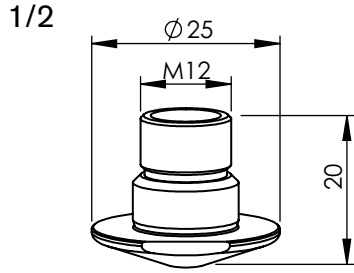

Consumables

	Centricut part number	Esse A part number	Reference number	Description	Pkg qty
1	MZ368-4430CP	L941X		MZ-Nozzle, 1.0 mm CP	1
	MZ368-4470CP	L942X	46143304470	MZ-Nozzle, 1.2 mm CP	1
	MZ368-4450CP	L943X	46143304450	MZ-Nozzle, 1.5 mm CP	1
	MZ368-4460CP	L944X	46143304460	MZ-Nozzle, 2.0 mm CP	1
	MZ368-4480CP	L945X	46143304480	MZ-Nozzle, 2.5 mm CP	1
	MZ368-4490CP	L946X	46143304490	MZ-Nozzle, 3.0 mm CP	1
	MZ368-4500CP	L947X	46143304500	MZ-Nozzle, 3.5 mm CP	1
	MZ368-4510CP	L948X	46143304510	MZ-Nozzle, 4.0 mm CP	1
2	MZ373-0001	L952X		MZ-Nozzle double, 1.2 mm CP	1
	MZ368-0005CP	L953X	46143306450	MZ-Nozzle double, 1.5 mm CP	1
	MZ373-0003	L954X	46143306460	MZ-Nozzle double, 2.0 mm CP	1
	MZ373-0004	L955X	46143306480	MZ-Nozzle double, 2.5 mm CP	1
	MZ373-0005	L956X	46143306490	MZ-Nozzle double, 3.0 mm CP	1
	MZ373-0007	L958X	46143306510	MZ-Nozzle double, 4.0 mm CP	1
3	MZ368-0740	AL363	36143310740	MZ-Nozzle holder	1
4	MZ368-0001	AL242	36143304420	MZ-Nozzle holder Hyper Gear	1

Centricut is not affiliated with the named manufacturers. Reference to machines, parts, descriptions, and model numbers are for convenience in verifying compatibility only. All parts are made by or for Centricut and are not made by the referenced manufacturers (unless expressly indicated). Centricut is a registered trademark of Hypertherm, Inc. All other trademarks are the properties of their respective owners.

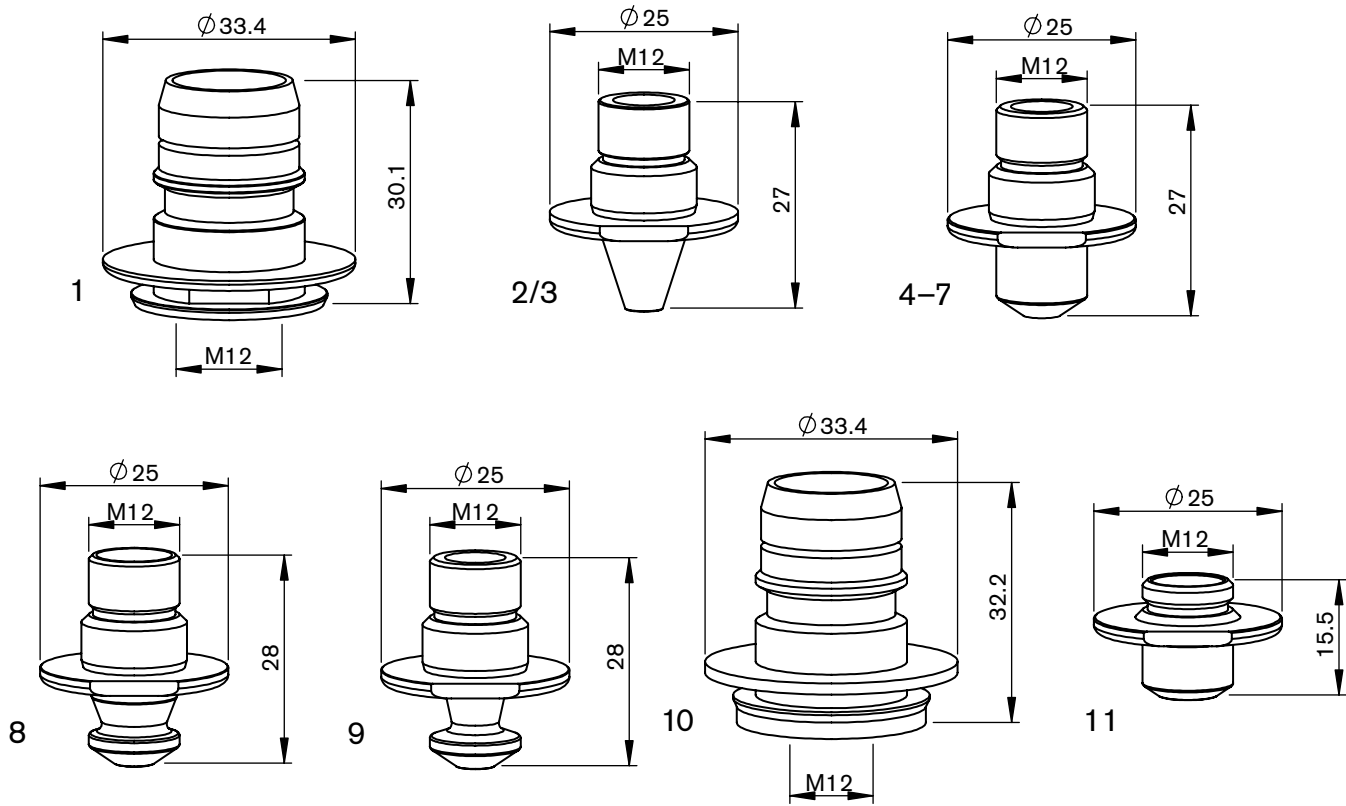

Consumables

	Centricut part number	Esse A part number	Reference number	Description	Pkg qty
1	MZ368-0522	AL362	36143310522E, 36143310522,36143310523	MZ-Nozzle holder	1
2	MZ373-0310CPX	L301380X	46143310332	MZ-Nozzle slim, 1.0 mm CP (10 pk)*	10
	MZ373-0341CPX	L301381X	46143310341, 46143310342, 46143310343	MZ-Nozzle slim, 1.2 mm CP (10 pk)*	10
	MZ373-0351CPX	L301382X	46143310351, 46143310352, 46143310353	MZ-Nozzle slim, 1.5 mm CP (10 pk)*	10
	MZ373-0361CPX	L301383X	46143310361, 46143310362, 46143310363	MZ-Nozzle slim, 2.0 mm CP (10 pk)*	10
	MZ373-0371CPX	L301384X	46143310371, 46143310372, 46143310373	MZ-Nozzle slim, 2.5 mm CP (10 pk)*	10
	MZ373-0381CPX	L301385X	46143310381, 46143310382, 46143310383	MZ-Nozzle slim, 3.0 mm CP (10 pk)*	10
	MZ373-0391CPX	L301386X	46143310391, 46143310392, 46143310393	MZ-Nozzle slim, 3.5 mm CP (10 pk)*	10
	MZ373-0401CPX	L301387X	46143310401, 46143310402, 46143310403	MZ-Nozzle slim, 4.0 mm CP (10 pk)*	10
3	MZ373-0312CPX	L301399X		MZ-Nozzle double slim, 1.2 mm CP (10 pk)*	10
	MZ373-0315CPX	L301392X	36143311500	MZ-Nozzle double slim, 1.5 mm CP (10 pk)*	10
	MZ373-0320CPX	L301393X	36143311510, 36143311512	MZ-Nozzle double slim, 2.0 mm CP (10 pk)*	10
	MZ373-0325CPX	L301394X	36143311520, 36143311522	MZ-Nozzle double slim, 2.5 mm CP (10 pk)*	10
	MZ373-0330CPX	L301395X	36143311530, 36143311532	MZ-Nozzle double slim, 3.0 mm CP (10 pk)*	10
	MZ373-0340CPX	L301397X	36143312390	MZ-Nozzle double slim, 4.0 mm CP (10 pk)*	10
	MZ373-0350CPX	L301512X		MZ-Nozzle double slim, 5.0 mm CP (10 pk)*	10

(Continued on next page)

Consumables

	Centricut part number	Esse A part number	Reference number	Description	Pkg qty
4	MZ373-1581CPX	L301581X	Q6143312210, 06283301190	MZ-Nozzle pencil, 1.0 mm CP (10 pk)*	10
	MZ373-1582CPX	L301582X	36143312220	MZ-Nozzle pencil, 1.2 mm CP (10 pk)*	10
	MZ373-1583CPX	L301583X	36143312230	MZ-Nozzle pencil, 1.5 mm CP (10 pk)*	10
	MZ373-1584CPX	L301584X	Q6143300060	MZ-Nozzle pencil, 1.8 mm CP (10 pk)*	10
	MZ373-1585CPX	L301585X	36143312240	MZ-Nozzle pencil, 2.0 mm CP (10 pk)*	10
	MZ373-1587CPX	L301587X	36143312250	MZ-Nozzle pencil, 2.5 mm CP (10 pk)*	10
	MZ373-1588CPX	L301588X	36143312260	MZ-Nozzle pencil, 3.0 mm CP (10 pk)*	10
	MZ373-1589CPX	L301589X	36143312270	MZ-Nozzle pencil, 3.5 mm CP (10 pk)*	10
	MZ373-1590CPX	L301590X	36143312280	MZ-Nozzle pencil, 4.0 mm CP (10 pk)*	10
	MZ373-1591CPX	L301591X	06143355590	MZ-Nozzle pencil, 4.5 mm CP (10 pk)*	10
	MZ373-1592CPX	L301592X	06283301030	MZ-Nozzle pencil, 5.0 mm CP (10 pk)*	10
	MZ373-1593CPX	L301593X	06283301830	MZ-Nozzle pencil, 5.5 mm CP (10 pk)*	10
5	MZ373-1601CPX	L301601X		MZ-Nozzle double pencil, 1.0 mm CP (10 pk)*	10
	MZ373-1602CPX	L301602X	Q6143300080	MZ-Nozzle double pencil, 1.2 mm CP (10 pk)*	10
	MZ373-1603CPX	L301603X	36143312300	MZ-Nozzle double pencil, 1.5 mm CP (10 pk)*	10
	MZ373-1604CPX	L301604X	36143312310	MZ-Nozzle double pencil, 1.8 mm CP (10 pk)*	10
	MZ373-1605CPX	L301605X	36143312311	MZ-Nozzle double pencil, 2.0 mm CP (10 pk)*	10
	MZ373-1607CPX	L301607X	36143312320	MZ-Nozzle double pencil, 2.5 mm CP (10 pk)*	10
	MZ373-1608CPX	L301608X	36143312330	MZ-Nozzle double pencil, 3.0 mm CP (10 pk)*	10
	MZ373-1609CPX	L301609X	36143312340	MZ-Nozzle double pencil, 3.5 mm CP (10 pk)*	10
	MZ373-1610CPX	L301610X	36143312350	MZ-Nozzle double pencil, 4.0 mm CP (10 pk)*	10
	MZ373-1611CPX	L301611X	06143312360	MZ-Nozzle double pencil, 4.5 mm CP (10 pk)*	10
MZ373-1612CPX	L301612X	06143312370	MZ-Nozzle double pencil, 5.0 mm CP (10 pk)*	10	
6	MZ373-1614CPX	L301614X	Q6260700010	MZ-Nozzle double pencil, 4.0 mm/inner 1.2 mm CP (10 pk)*	10
	MZ373-1615CPX	L301615X	06143355360	MZ-Nozzle double pencil, 4.0 mm/inner 1.4 mm CP (10 pk)*	10
	MZ373-1616CPX	L301616X	06143355370	MZ-Nozzle double pencil, 4.0 mm/inner 1.8 mm CP (10 pk)*	10
	MZ373-1617CPX	L301617X	06283301050	MZ-Nozzle double pencil, 4.5 mm/inner 1.2 mm CP (10 pk)*	10
	MZ373-1618CPX	L301618X	06283301200	MZ-Nozzle double pencil, 5.0 mm/inner 1.2 mm CP (10 pk)*	10
	MZ373-1619CPX	L301619X	06283301210	MZ-Nozzle double pencil, 5.5 mm/inner 1.2 mm CP (10 pk)*	10
	MZ373-1686CPX	L301686X	06283301840	MZ-Nozzle double pencil, 5.5 mm/inner 2.0 mm CP (10 pk)*	10
MZ373-1688X	L301688X	06283302110	MZ-Nozzle double pencil, 7.0 mm/inner 1.8 mm CP (10 pk)*	10	
7	MZ373-1574	L1574X	Q6143300040	MZ-Nozzle double pencil SUS, 4.5 mm CP	1
8	MZ373-1820CPX	L301829X	06283301820	MZ-Nozzle double pencil, 1.5 mm HP CP (10 pk)*	10
9	MZ373-1790CPX	L301816X	06283301790	MZ-Nozzle pencil, 1.0 mm HP CP (10 pk)*	10
	MZ373-1800CPX	L301817X	06283301800	MZ-Nozzle pencil, 1.2 mm HP CP (10 pk)*	10
	MZ373-1812CPX NEW	L301812X	06283303690	MZ-Nozzle pencil, 1.3 mm HP CP (10 pk)*	10
	MZ373-1813CPX NEW	L301813X	06283303700	MZ-Nozzle pencil, 1.4 mm HP CP (10 pk)*	10
	MZ373-1810CPX	L301818X	06283301810	MZ-Nozzle pencil, 1.5 mm HP CP (10 pk)*	10
10	MZ373-0465	AL465	Q6283300040	MZ-Nozzle holder	1
11	MZ373-0030	L1890	Q6283300030	MZ-Nozzle double smooth, 6.0 mm	1
	MZ373-0020	L1891	Q6283300020	MZ-Nozzle double smooth, 7.5 mm	1
	MZ373-0010	L1892	Q6283300010	MZ-Nozzle double smooth, 9.5 mm	1

* Centricut parts available in single packs. To order single packs, remove the 'X' at the end of the part number (e.g. AM123-4567X would be AM123-4567).

For Esse A parts available in single packs. To order single packs, remove the '30' after the L in the part number (e.g. L301401X would be L401X).

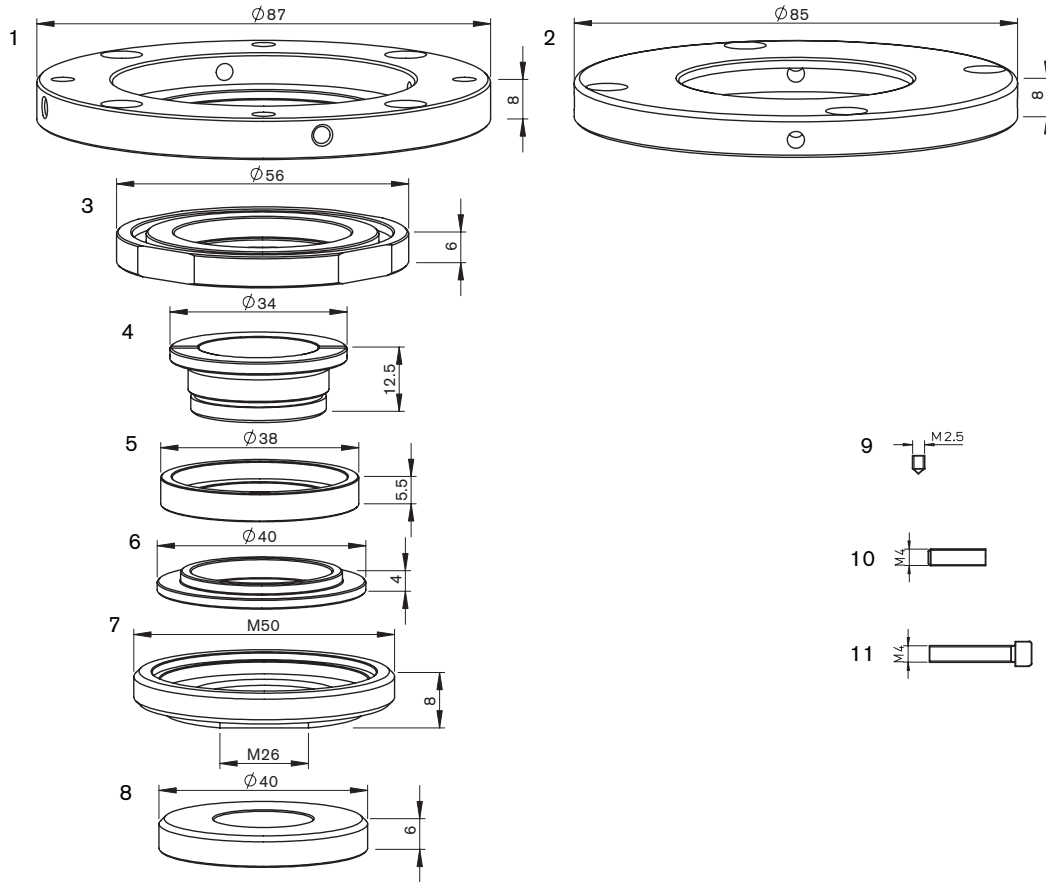

Consumables

	Centricut part number	Esse A part number	Reference number	Description	Pkg qty
1	MZ413-0332	AL320	3614330332	MZ-Ring, aluminum	1
2	MZ413-0630	AL492	06283300630	MZ-Ring, aluminum	1
3	MZ413-0620	AL491	06283300620	MZ-Ring, brass	1
	MZ413-0320	AL316	46143300320	MZ-Ring, brass	1
4	MZ413-0280	AL288	46143300280, 46143300281, 46143300282	MZ-Retainer nut	1
5	MZ408-0270	AL286	46143300270	MZ-Ring, ceramic	1
	MZ413-0270	AL386	46143300270	MZ-Insulating, PTFE*	1
6	MZ408-0260	AL285	46143300260C	MZ-Ring, ceramic	1
	MZ413-0260	AL385	46143300260	MZ-Insulating, PTFE*	1
7	MZ413-0290	AL294	46143300290	MZ-Retainer nut	1
8	MZ408-4440	AL290	46143304440	MZ-Ring, ceramic	1
	MZ413-4440	AL390	46143304440	MZ-Insulating, PTFE*	1
9	MZ413-1180	AL322	46183301180	MZ-Screw	1
10	MZ413-0010	AL321	A51NX000210	MZ-Screw (4 pcs)	4
11	MZ413-0200	AL319	A06CB040200, A06CB040160, A06CB040100	MZ-Set screw (4 pcs)	4

(Continued on next page)

Centricut is not affiliated with the named manufacturers. Reference to machines, parts, descriptions, and model numbers are for convenience in verifying compatibility only. All parts are made by or for Centricut and are not made by the referenced manufacturers (unless expressly indicated). Centricut is a registered trademark of Hypertherm, Inc. All other trademarks are the properties of their respective owners.

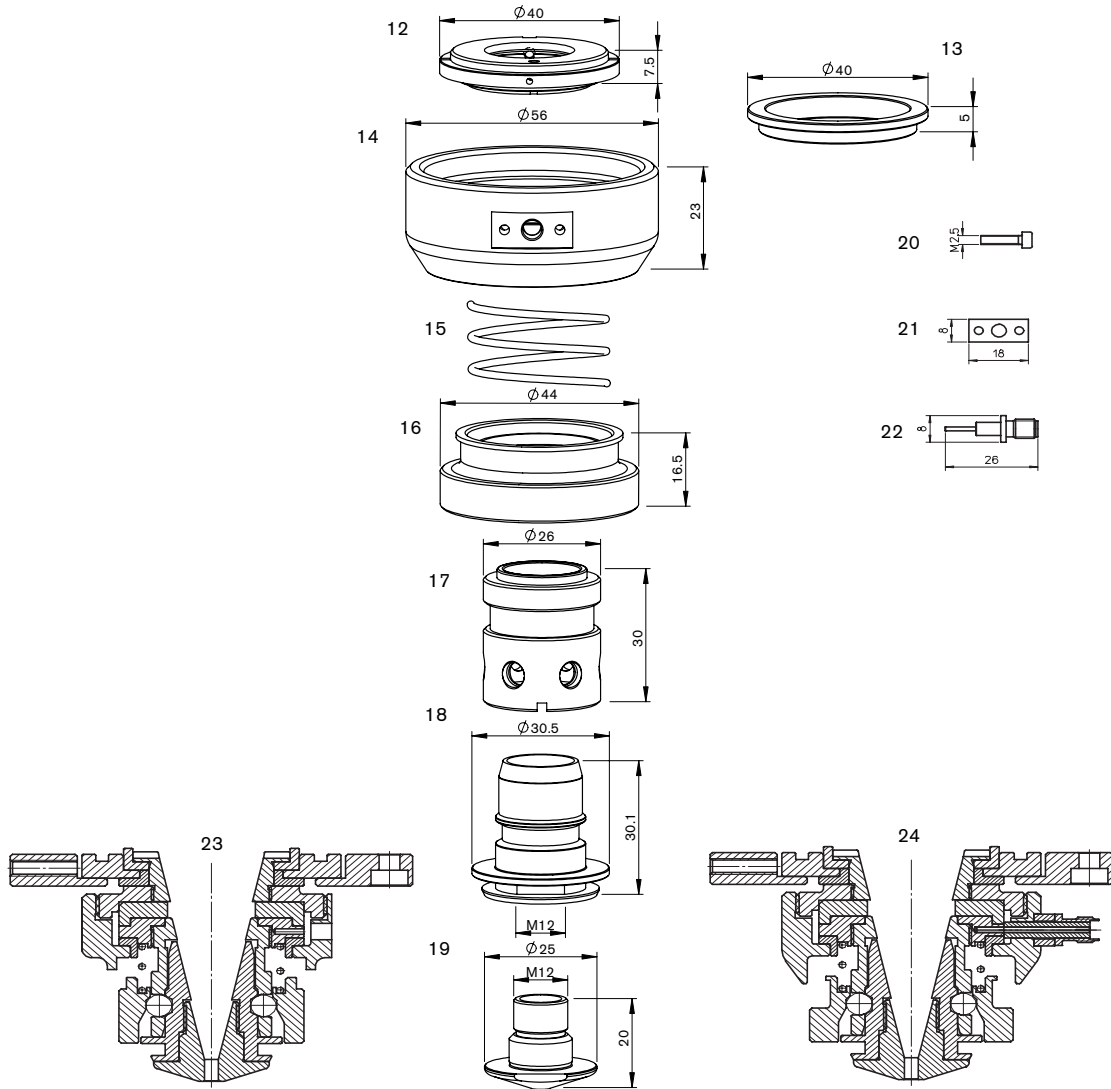

Consumables

	Centricut part number	Esse A part number	Reference number	Description	Pkg qty
12	MZ413-7420	AL295	46143307420, 46143307421	MZ-Retainer nut	1
13	MZ408-0240	AL284	46143300240	MZ-Ring, ceramic	1
	MZ413-0240	AL384	46143300240T	MZ-Insulating, PTFE*	1
14	MZ413-7980	AL313	36143307980	MZ-Body, aluminum	1
15	MZ413-0220	AL289	46143300220	MZ-Spring	1
16	MZ413-8000	AL314	46143308000	MZ-Spring retainer, steel	1
17	MZ413-4400	AL291	36143304400, 36143304401	MZ-Coupler	1
	MZ413-0230 (not shown)	AL311	46143300230	MZ-Ball kit replacement (6 pcs)	1
18	MZ368-0001	AL242	36143304420	MZ-Nozzle holder Hyper Gear	1
19	Please refer to the Mazak [®] nozzle section				
20	MZ413-0030	AL317	46603300030, A05GS002560	MZ-Screw	1
21	MZ413-8170	AL318	46143308170	MZ-Spacer	1
22	MZ413-8190	AL315	46143308190	MZ-Connector	1
23	MZ413-0001	TMA50/C		MZ-Complete head (ceramic insulating)	1
24	MZ413-0002	TMA40/C		MZ-Complete head (ceramic insulating)	1

*PolyTetraFluoroEthylene is a fluorocarbon-based polymer and is commonly abbreviated PTFE. The Teflon[®] brand of PTFE is manufactured only by DuPont and is not sold by Hypertherm. Hypertherm purchases other brands of PTFE from various high quality manufacturers.

HyperGear – PFP torch

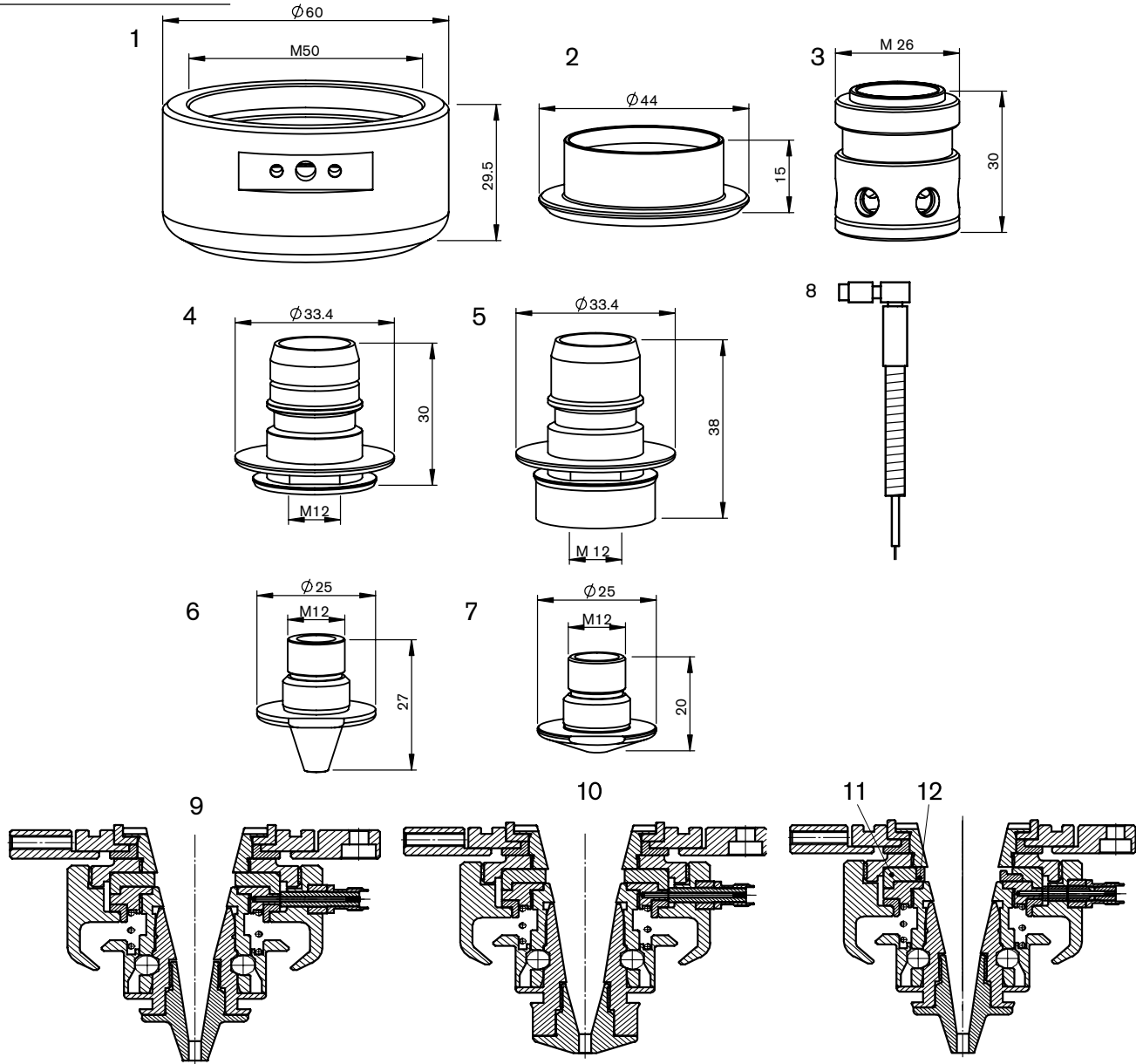

Consumables

	Centricut part number	Esse A part number	Reference number	Description	Pkg qty
	1 MZ368-0550	AL365	36143310550	MZ-Body, aluminum	1
	2 MZ368-0541	AL366	36143310541, 36143310542	MZ-Retainer, steel	1
	3 MZ368-0530	AL367	36143310530, 36143310531	MZ-Coupler	1
	4 MZ368-0522	AL362	36143310522E, 36143310522, 36143310523	MZ-Nozzle holder	1
	5 MZ368-0740	AL363	36143310740	MZ-Nozzle holder	1
	6	Please refer to the Mazak® slim nozzle section			
	7	Please refer to the Mazak® nozzle section			
	8 MZ335-8290	AL368	46143308290	MZ-Sensor cable, 75 mm (3")	1
	9 MZ368-0060	TMA60/C		MZ-Head w/ceramic spacer	1
	10 MZ368-0070	TMA70/C		MZ-Head w/ceramic spacer	1
11/12	MZ368-2180	AL463	46143312180	MZ-Ring, 23x4 ceramic	1
	MZ368-2170	AL464	46143312170	MZ-Ring 40x6, PPS	1

Centricut is not affiliated with the named manufacturers. Reference to machines, parts, descriptions, and model numbers are for convenience in verifying compatibility only. All parts are made by or for Centricut and are not made by the referenced manufacturers (unless expressly indicated). Centricut is a registered trademark of Hypertherm, Inc. All other trademarks are the properties of their respective owners.

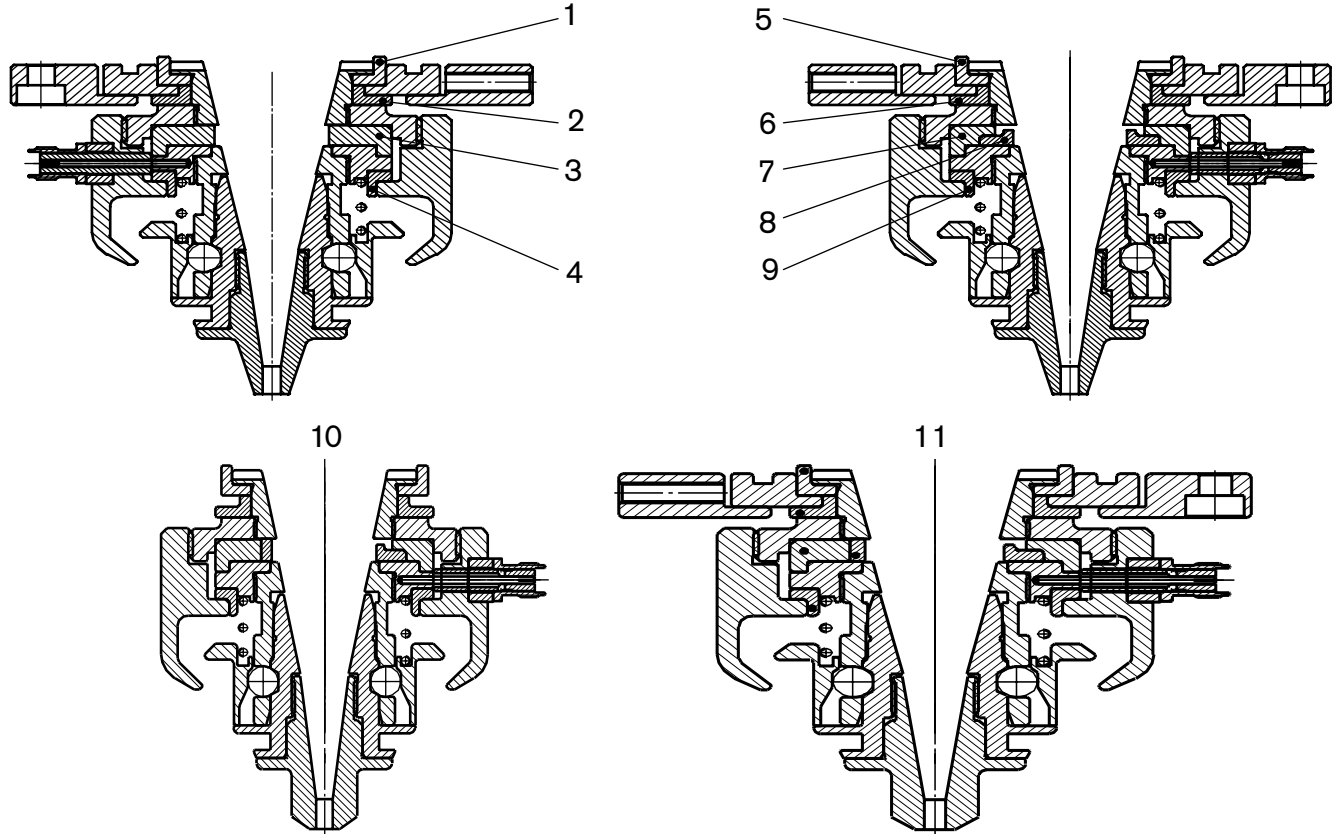

Consumables

	Centricut part number	Esse A part number	Reference number	Description	Pkg qty
1	MZ408-0270	AL286	46143300270	MZ-Ring, ceramic	1
	MZ413-0270	AL386	46143300270	MZ-Insulating, PTFE*	1
2	MZ408-0260	AL285	46143300260C	MZ-Ring, ceramic	1
	MZ413-0260	AL385	46143300260	MZ-Insulating, PTFE*	1
3	MZ408-4440	AL290	46143304440	MZ-Ring, ceramic	1
	MZ413-4440	AL390	46143304440	MZ-Insulating, PTFE*	1
4	MZ408-0240	AL284	46143300240	MZ-Ring, ceramic	1
	MZ413-0240	AL384	46143300240T	MZ-Insulating, PTFE*	1
5	MZ368-2100	AL486	46143312100, 46143312101	MZ-Insulating ring, 38x5.5 PPS	1
6	MZ368-2130	AL485	46143312130	MZ-Insulating ring, 40x4 PPS	1
7	MZ368-2080	AL490	46143312080	MZ-Spacer 40x6, PPS	1
8	MZ368-2090	AL487	46143312090	MZ-Ring, 30x3 ceramic	1
9	MZ368-2120	AL484	46143312120	MZ-Insulating ring, 40x5 PPS	1
10	MZ368-0085	TMA85	TMA85	MZ-Head w/PPS spacer	1
11	MZ368-0080	TMA80	TMA80	MZ-Head w/PPS spacer	1

*PolyTetraFluoroEthylene is a fluorocarbon-based polymer and is commonly abbreviated PTFE. The Teflon[®] brand of PTFE is manufactured only by DuPont and is not sold by Hypertherm. Hypertherm purchases other brands of PTFE from various high quality manufacturers.

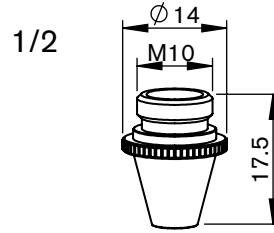

Consumables

	Centricut part number	Esse A part number	Reference number	Description	Pkg qty
	MZ322-0512X	L3077	46603350512	MZ-Nozzle, 1.2 mm (10 pk)	10
	PT322-0520X	L30127	4660335052B	PT-Nozzle, 1.5 mm (10 pk)	10
	MZ322-0517X	L30281	46603350517-1,8	MZ-Nozzle, 1.8 mm (10 pk)*	10
	MZ322-0522X	L3080	4660335052C	MZ-Nozzle, 2.0 mm (10 pk)	10
	MZ322-0022X	L30282	46603350522-2,2	MZ-Nozzle, 2.2 mm (10 pk)*	10
	MZ322-0025X	L30124	46603350525	MZ-Nozzle, 2.5 mm (10 pk)	10
	MZ322-0030X	L30150	46603350530	MZ-Nozzle, 3.0 mm (10 pk)	10
	MZ322-1035X	L30708	46603350530-3,5	MZ-Nozzle, 3.5 mm (10 pk)	10
	MZ322-1040X	L30709	46603350530-4,0	MZ-Nozzle, 4.0 mm (10 pk)	10
2	MZ322-0512CPX	L3077X	46603350512	MZ-Nozzle, 1.2 mm CP (10 pk)*	10
	PT322-0520CPX	L30127X	4660335052B	PT-Nozzle, 1.5 mm CP (10 pk)*	10
	MZ322-0522CPX	L3080X	4660335052C	MZ-Nozzle, 1.8 mm CP (10 pk)*	10
	MZ322-0030CPX	L30150X	46603350530	MZ-Nozzle, 3.0 mm CP (10 pk)*	10

* Centricut parts available in single packs. To order single packs, remove the 'X' at the end of the part number (e.g. AM123-4567X would be AM123-4567).
For Esse A parts available in single packs. To order single packs, remove the '30' after the L in the part number (e.g. L301401X would be L401X).

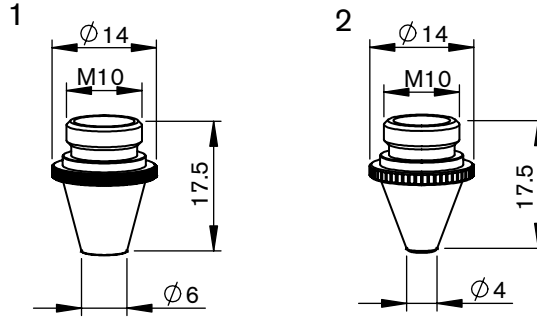

Consumables

	Centricut part number	Esse A part number	Reference number	Description	Pkg qty
1	MZ346-0002X	L30616		MZ-Nozzle double, 1.2 mm (10 pk)*	10
	MZ346-0003X	L30617	46683302400	MZ-Nozzle double, 1.5 mm (10 pk)*	10
	MZ346-0006X	L30620	46683302390	MZ-Nozzle double, 2.0 mm (10 pk)*	10
	MZ346-0008X	L30622	46683302400	MZ-Nozzle double, 2.5 mm (10 pk)*	10
	MZ346-0009X	L30623	46683302410	MZ-Nozzle double, 3.0 mm (10 pk)*	10
	MZ346-0002CPX	L30616X		MZ-Nozzle double, 1.2 mm CP (10 pk)*	10
	MZ346-0003CPX	L30617X	46683302380	MZ-Nozzle double, 1.5 mm CP (10 pk)*	10
	MZ346-0004CPX	L30618X		MZ-Nozzle double, 1.7 mm CP (10 pk)	10
	MZ346-0006CPX	L30620X	46683302390	MZ-Nozzle double, 2.0 mm CP (10 pk)*	10
	MZ346-0007CPX	L30621X		MZ-Nozzle double, 2.2 mm CP (10 pk)	10
	MZ346-0008CPX	L30622X	46683302400	MZ-Nozzle double, 2.5 mm CP (10 pk)*	10
	MZ346-0009CPX	L30623X	46683302410	MZ-Nozzle double, 3.0 mm CP (10 pk)*	10
		MZ321-0010X	L30250	46603350521	MZ-Nozzle, 1.0 mm (10 pk)
	MZ321-0012X	L30251	46603350521	MZ-Nozzle, 1.2 mm (10 pk)	10
	MZ321-0520X	L30252	46603350520	MZ-Nozzle, 1.5 mm (10 pk)	10
	MZ321-0017X	L30253	46603350521	MZ-Nozzle, 1.7 mm (10 pk)	10
	MZ321-0054X	L30254	46603350522	MZ-Nozzle, 2.0 mm (10 pk)	10
	MZ321-1025X	L30770	46603350522	MZ-Nozzle, 2.5 mm (10 pk)	10
	MZ321-1030X	L30771	46683301281	MZ-Nozzle, 3.0 mm (10 pk)	10
	MZ321-0054CPX	L30254X	46603350522	MZ-Nozzle, 2.0 mm CP (10 pk)	10

* Centricut parts available in single packs. To order single packs, remove the 'X' at the end of the part number (e.g. AM123-4567X would be AM123-4567).
For Esse A parts available in single packs. To order single packs, remove the '30' after the L in the part number (e.g. L301401X would be L401X).

1-2

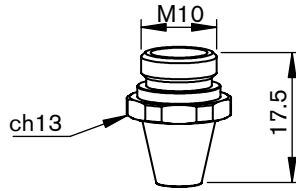

Consumables

	Centricut part number	Esse A part number	Reference number	Description	Pkg qty
1	MZ385-0511X	L30726	46603350511	MZ-Nozzle hexagonal, 1.0 mm (10 pk)*	10
	MZ385-5052X	L30727	4660335052A	MZ-Nozzle hexagonal, 1.2 mm (10 pk)*	10
	MZ385-5052BX	L30728	4660335052B	MZ-Nozzle hexagonal, 1.5 mm (10 pk)*	10
	MZ385-5052CX	L30731	4660335052C	MZ-Nozzle hexagonal, 2.0 mm (10 pk)*	10
	MZ385-0003X	L30733	4660335052D	MZ-Nozzle hexagonal, 2.5 mm (10 pk)*	10
	MZ385-1003X	L30734	46603350530	MZ-Nozzle hexagonal, 3.0 mm (10 pk)	10
2	MZ385-0052CPX	L30731X	4660335052C	MZ-Nozzle hexagonal, 2.0 mm CP (10 pk)*	10
	MZ385-0003CPX	L30733X	4660335052D	MZ-Nozzle hexagonal, 2.5 mm CP (10 pk)	10
	MZ385-1003CPX	L30734X	46603350530	MZ-Nozzle hexagonal, 3.0 mm CP (10 pk)	10

* Centricut parts available in single packs. To order single packs, remove the 'X' at the end of the part number (e.g. AM123-4567X would be AM123-4567).
For Esse A parts available in single packs. To order single packs, remove the '30' after the L in the part number (e.g. L301401X would be L401X).

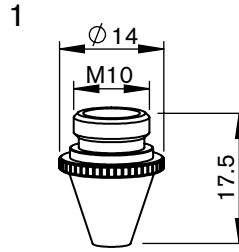

Consumables

	Centricut part number	Esse A part number	Reference number	Description	Pkg qty
1	MZ322-0523-1.5	L493		MZ-Nozzle shower, 1.5 mm	1
	MZ322-0523-2.0	L497		MZ-Nozzle shower, 2.0 mm	1

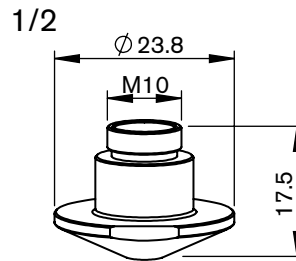

Consumables

	Centricut part number	Esse A part number	Reference number	Description	Pkg qty	
1	MZ335-0011	L423		MZ-Nozzle, 1.2 mm	1	
	MZ335-1950	L429	46683301950	MZ-Nozzle, 1.5 mm	1	
	MZ335-1821	L430	46683301821	MZ-Nozzle, 2.0 mm	1	
	MZ335-1960	L431	46683301960	MZ-Nozzle, 2.5 mm	1	
	MZ335-1970	L432	46683301970	MZ-Nozzle, 3.0 mm	1	
	MZ335-0006	L472		MZ-Nozzle, 3.5 mm	1	
	MZ335-0013	L473		MZ-Nozzle, 4.0 mm	1	
	MZ335-1950CP	L429X	46683301950	MZ-Nozzle, 1.5 mm CP	1	
	MZ335-1821CP	L430X	46683301821	MZ-Nozzle, 2.0 mm CP	1	
	MZ335-1960CP	L431X	46683301960	MZ-Nozzle, 2.5 mm CP	1	
	MZ335-1970CP	L432X	46683301970	MZ-Nozzle, 3.0 mm CP	1	
	2	MZ360-0002	L851		MZ-Nozzle double, 1.2 mm	1
		MZ360-0003	L852	46683302420	MZ-Nozzle double, 1.5 mm	1
MZ360-0005		L853	46683302430	MZ-Nozzle double, 2.0 mm	1	
MZ360-0007		L854		MZ-Nozzle double, 2.5 mm	1	
MZ360-0008		L855	46683302450	MZ-Nozzle double, 3.0 mm	1	
MZ360-0003CP		L852X	46683302420	MZ-Nozzle double, 1.5 mm CP	1	
MZ360-0005CP		L853X	46683302430	MZ-Nozzle double, 2.0 mm CP	1	
MZ360-0008CP		L855X		MZ-Nozzle double, 3.0 mm CP	1	

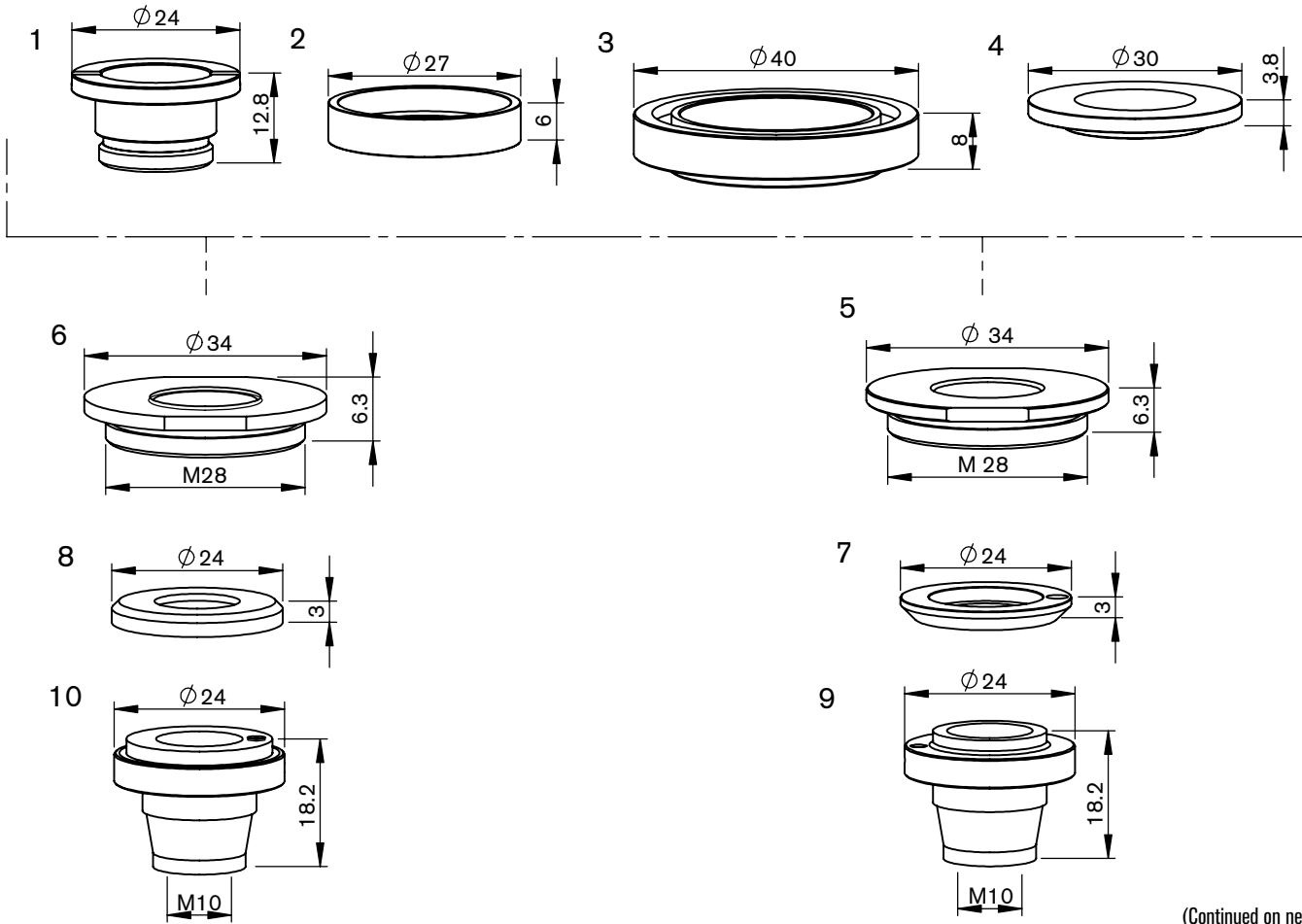

(Continued on next page)

Consumables

	Centricut part number	Esse A part number	Reference number	Description	Pkg qty
1	MZ335-1110	AL74	46683301110, 46773300500	MZ-Bracket, copper	1
2	MZ335-1080	AL80	46683302081, 46683301080	MZ-Spacer 27x5.5, PTFE*	1
	MZ335-1080P	AL80/P	46683302081, 46683301080	MZ-Ring, plastic	1
	MZ335-1080C	AL280	46683302081, 46683301080	MZ-Ring, ceramic	1
	MZ335-1080M	ALM280	46683301080, 46683302081	MZ-Spacer 27x5.5, ceramic	1
	MZ309-3200 (not shown)	AL97		MZ-O-ring external base	1
3	MZ335-1070	AL84	46683301070	MZ-Base, brass	1
4	MZ335-1090	AL79	46683301090, 46683302091	MZ-Spacer 30x4, PTFE*	1
	MZ335-0090C	AL79/P	46683301090, 46683302091	MZ-Spacer 30x4, special	1
	MZ335-1090C	AL279	46683301090, 46683302091	MZ-Ring, ceramic	1
	MZ335-1090M	ALM279	46683301090, 46683302091	MZ-Spacer 30x4, ceramic	1
	5	MZ335-1101	AL376	46773300510	MZ-Nut, copper
6	MZ335-1100	AL83	46683301100	MZ-Bracket, copper	1
7	MZ335-1120	AL77	46683301120	MZ-Spacer 24x3, PTFE*	1
	MZ335-1120LL	AL77/P	46683301120	MZ-Ring long life	1
	MZ335-1120C	AL277	46683301120	MZ-Ring, ceramic	1
8	MZ335-0710	AL377	46677330710	MZ-Ring, ceramic	1
	MZ335-0710M	ALM377	46773300710	MZ-Spacer 24x3, ceramic	1
9	MZ335-0850	AL75	46683300850	MZ-Nozzle body, copper	1
10	MZ335-0720	AL253	46773300720, 46773300721, 46683300720	MZ-Nozzle body, copper	1

Centricut is not affiliated with the named manufacturers. Reference to machines, parts, descriptions, and model numbers are for convenience in verifying compatibility only. All parts are made by or for Centricut and are not made by the referenced manufacturers (unless expressly indicated). Centricut is a registered trademark of Hypertherm, Inc. All other trademarks are the properties of their respective owners.

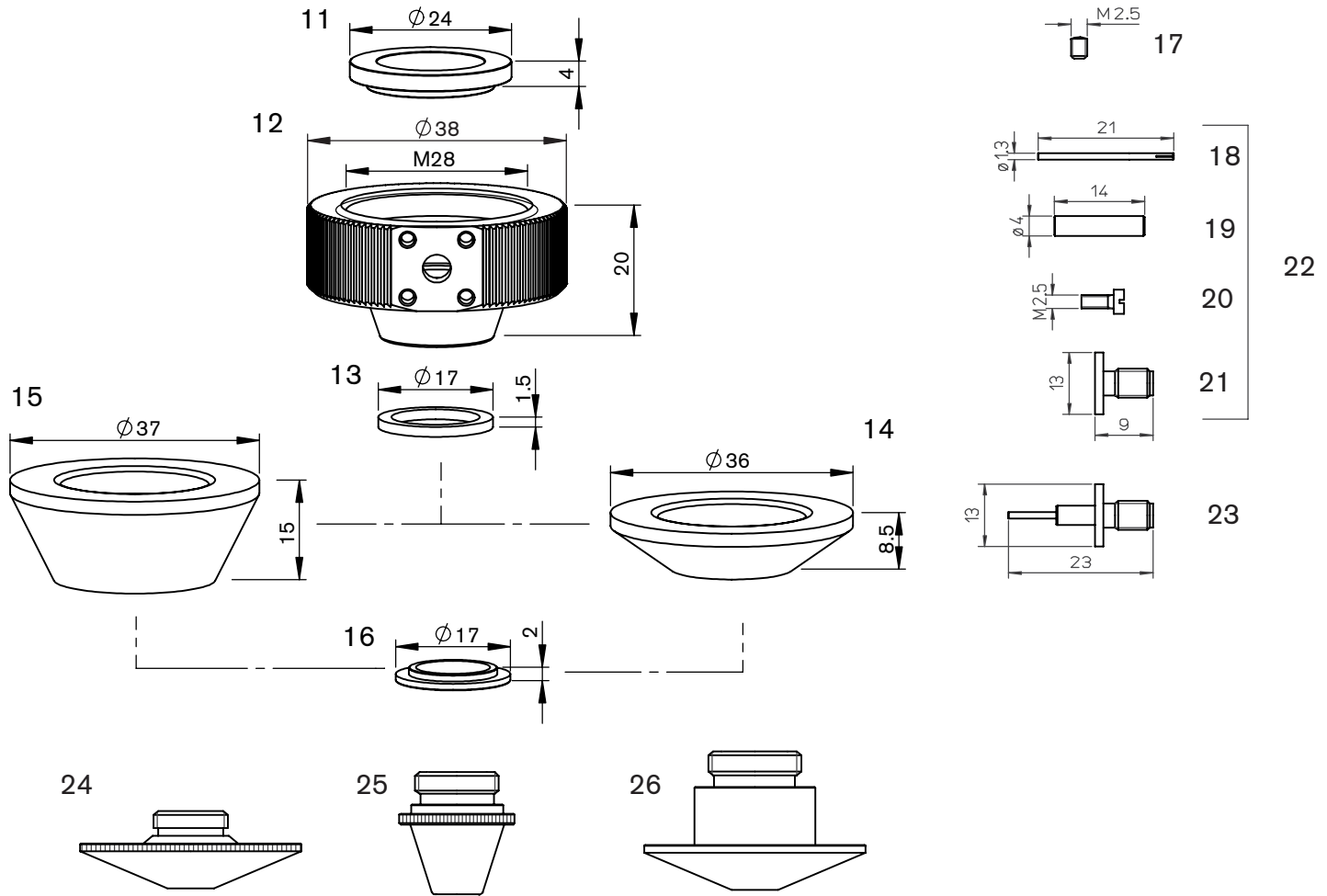

Consumables

	Centricut part number	Esse A part number	Reference number	Description	Pkg qty
11	MZ335-1130	AL78	46683301130, 46683302111	MZ-Spacer 24x4, PTFE*	1
	MZ335-1130LL	AL78/P	46683301130	MZ-Ring long life	1
	MZ335-1130C	AL278	46683301130	MZ-Spacer, ceramic	1
	MZ335-1130M	ALM278	46683301130	MZ-Spacer 24x4, ceramic	1
12	MZ335-1140	AL73	46683301140, 36773300530	MZ-Housing, aluminum	1
13	MZ335-1150	AL81	46683301150	MZ-Spacer 17x1.5, PTFE*	1
14	MZ335-1930	AL111	46683301930	MZ-Nozzle body cover	1
	MZ335-1930LL	AL111/P	46683301930P	MZ-Nozzle body cover, long life	1
	MZ335-0009	AL275	46683301930C	MZ-Protective cover, ceramic	1
15	MZ335-1841	AL118	46683301841	MZ-Nozzle cover	1
16	MZ335-1160	AL82	46683301160	MZ-Ring, 17x2, copper	1
17	MZ335-1180	AL119	46683301180	MZ-Bolt	1
18	MZ335-1170	AL76	46683301170	MZ-Contact	1
19	MZ335-0030	AL88	46683300030	MZ-Connecting pipe, PTFE *	1
20	MZ335-0000	AL127	46683300000	MZ-Screws for connector kit MZ335-0001 (4 pcs)	4
21	MZ335-1113	AL113	46683301170	MZ-Connector	1
22	MZ335-0001	AL154	46683301171, 46683301170, not assembled	MZ-Connector kit	1
23	MZ335-0001A	AL213	46683301171, 46683301170	MZ-Connector kit, assembled	1
24	Please refer to the Trumpf® nozzle section				
25	Please refer to the Mazak® nozzle section				
26	Please refer to the Mazak® nozzle section				

*PolyTetraFluoroEthylene is a fluorocarbon-based polymer and is commonly abbreviated PTFE. The Teflon® brand of PTFE is manufactured only by DuPont and is not sold by Hypertherm. Hypertherm purchases other brands of PTFE from various high quality manufacturers.

Centricut is not affiliated with the named manufacturers. Reference to machines, parts, descriptions, and model numbers are for convenience in verifying compatibility only. All parts are made by or for Centricut and are not made by the referenced manufacturers (unless expressly indicated). Centricut is a registered trademark of Hypertherm, Inc. All other trademarks are the properties of their respective owners.

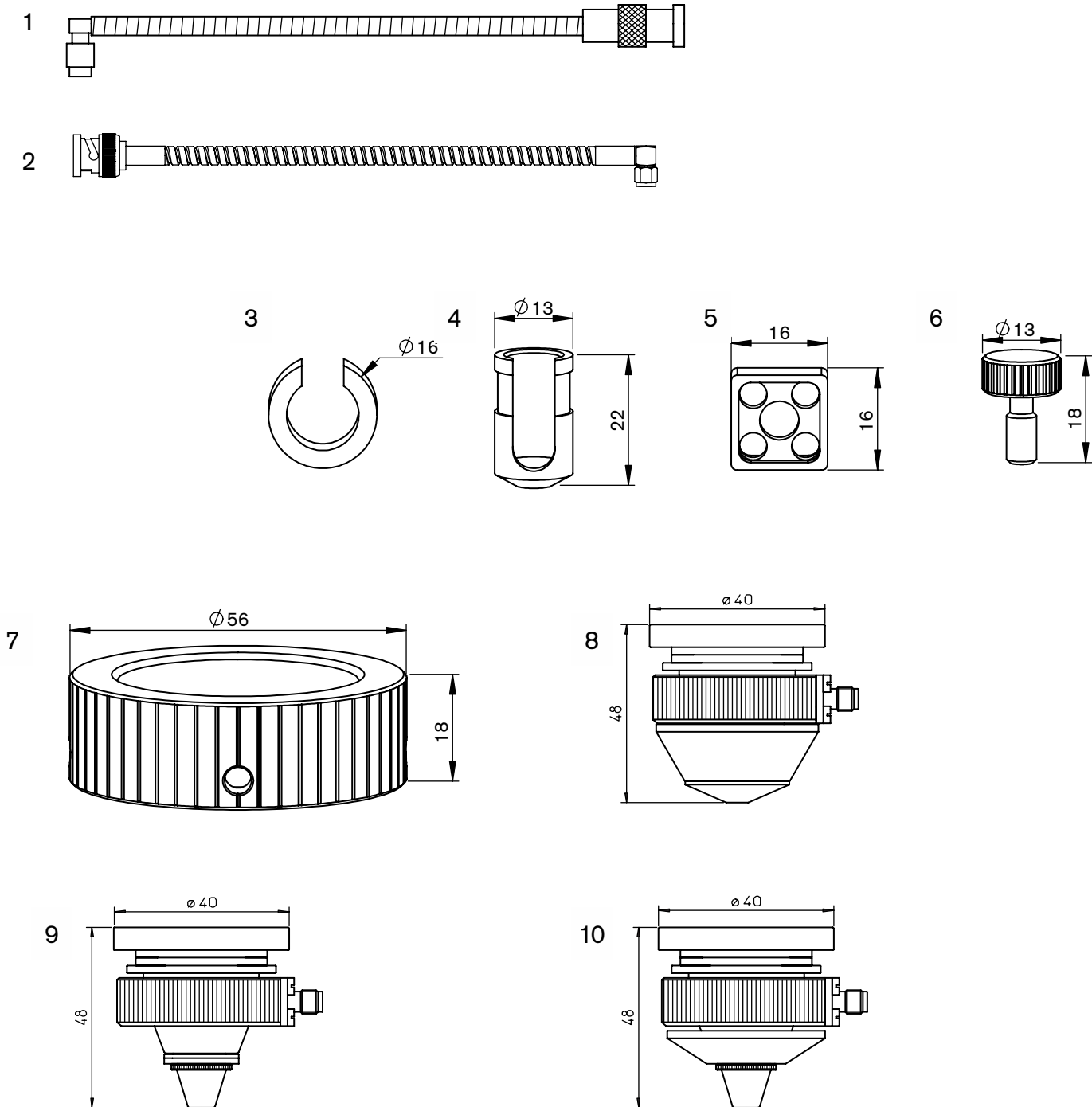

Consumables

	Centricut part number	Esse A part number	Reference number	Description	Pkg qty
1	MZ335-1980	AL103	46683301980, 46683301982	MZ-Sensor head connecting cable, short 280 mm (11")	1
	MZ335-1330	AL103/S	46683301330	MZ-Sensor head connecting cable, long 310 mm (12")	1
2	MZ335-1330A	AL622	46683301330	MZ-Sensor cable, 305 mm (12") armored	1
	MZ335-1980A	AL643	46683301980, 46683301982	MZ-Sensor cable, 280 mm (11") armored	1
3	MZ335-1870	AL155	46683301870, 46683301920	MZ-Cover clips	1

Centricut is not affiliated with the named manufacturers. Reference to machines, parts, descriptions, and model numbers are for convenience in verifying compatibility only. All parts are made by or for Centricut and are not made by the referenced manufacturers (unless expressly indicated). Centricut is a registered trademark of Hypertherm, Inc. All other trademarks are the properties of their respective owners.

Consumables

	Centricut part number	Esse A part number	Reference number	Description	Pkg qty
4	MZ335-1860	AL156	46683301860, 46683301910	MZ-Cable connector cover	1
	MZ335-1860LL	AL156/P	46683301860	MZ-Connector cover, long life	1
5	MZ335-1850	AL157	46683301851	MZ-Connector cover	1
	MZ335-1850P	AL157/P	46683301850, 46683301851	MZ-Cover, plastic	1
6	MZ335-0320	AL152	46683300032, 46603300032	MZ-Bolt M5 x 0.5	1
7	MZ335-0930	AL153	46683300930	MZ-Ring	1
8	MZ335-0002	TMA10		MZ-Head w/PTFE* spacer	1
	MZ335-1013	TMA10/C		MZ-Head w/ceramic spacer	1
	MZ335-0012	TMA10/P		MZ-Head w/long life spacer	1
9	MZ335-1014	TMA20		MZ-Head w/PTFE* spacer	1
	MZ335-0015	TMA20/P		MZ-Head w/long life spacer	1
	MZ335-0016	TMA20/C		MZ-Head w/ceramic spacer	1
10	MZ335-0017	TMA30		MZ-Head w/PTFE spacer	1
	MZ335-0018	TMA30/P		MZ-Head w/long life spacer	1
	MZ335-0019	TMA30/C		MZ-Head w/ceramic spacer	1

*PolyTetraFluoroEthylene is a fluorocarbon-based polymer and is commonly abbreviated PTFE. The Teflon® brand of PTFE is manufactured only by DuPont and is not sold by Hypertherm. Hypertherm purchases other brands of PTFE from various high quality manufacturers.

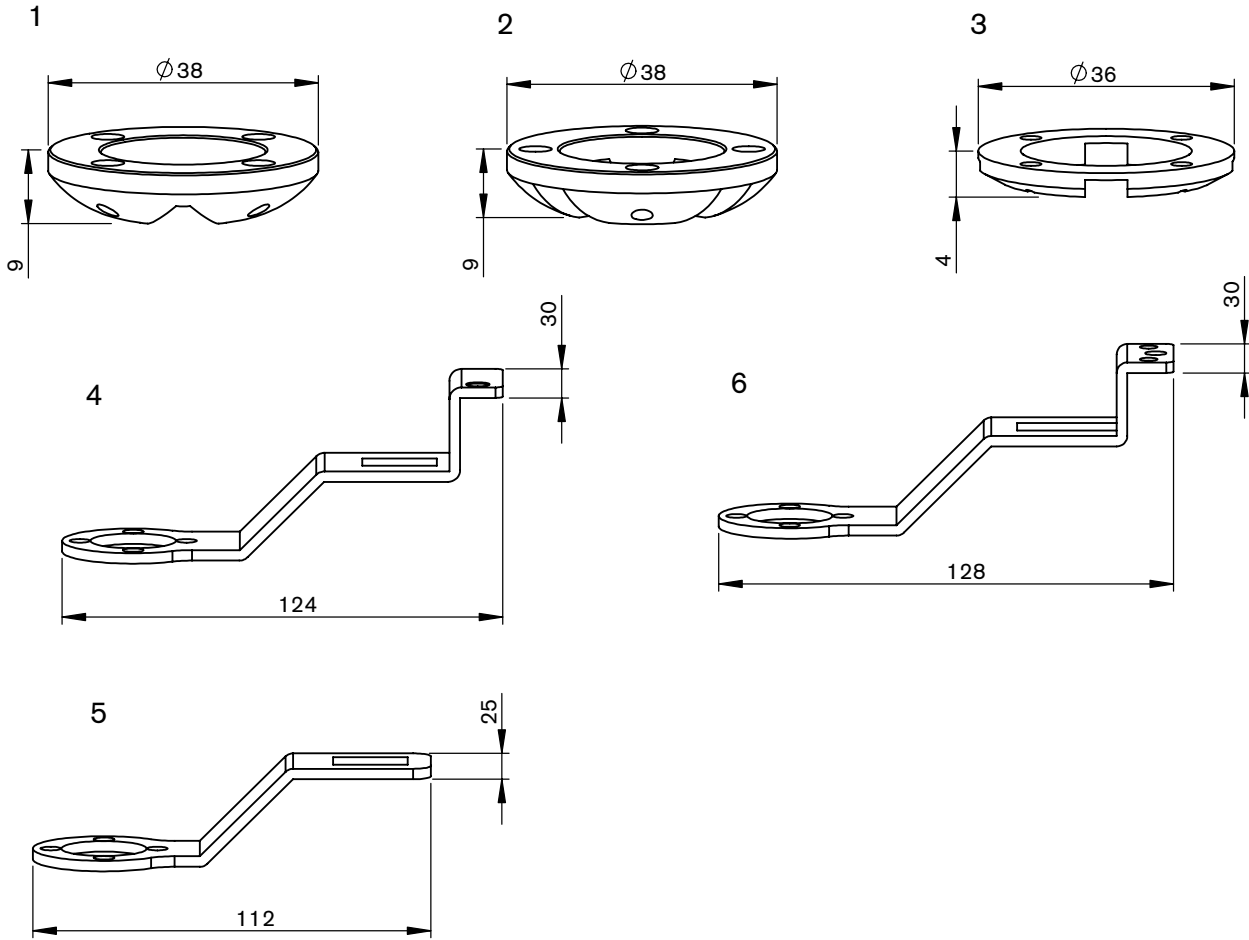

(5-7 not to scale)

Consumables

	Centricut part number	Esse A part number	Reference number	Description	Pkg qty
1	MZ309-5080	AL10	46602350080	MZ-Stylus foot H9, brass	1
	MZ309-1043	AL15	46572301043	MZ-Stylus foot H9, steel	1
	MZ309-1045	AL16	46572301045	MZ-Stylus foot H9, PTFE*	1
2	MZ309-0001	AL132		MZ-Stylus foot H9, brass	1
3	MZ309-0520	AL117	46512300520	MZ-Stylus foot H4, brass	1
4	MZ309-0580	AL66	36602300580	MZ-Stylus arm w/screw M6	1
5	MZ309-0560	AL60	36602300560, 36682300050	MZ-Stylus arm	1
6	MZ309-0281	AL167	36682300281	MZ-Stylus arm w/screw M6 and M5	1
	MZ309-001 (not shown)		68057488	MZ-Screws for stylus feet (10 pcs)	10

*PolyTetraFluoroEthylene is a fluorocarbon-based polymer and is commonly abbreviated PTFE. The Teflon[®] brand of PTFE is manufactured only by DuPont and is not sold by Hypertherm. Hypertherm purchases other brands of PTFE from various high quality manufacturers.

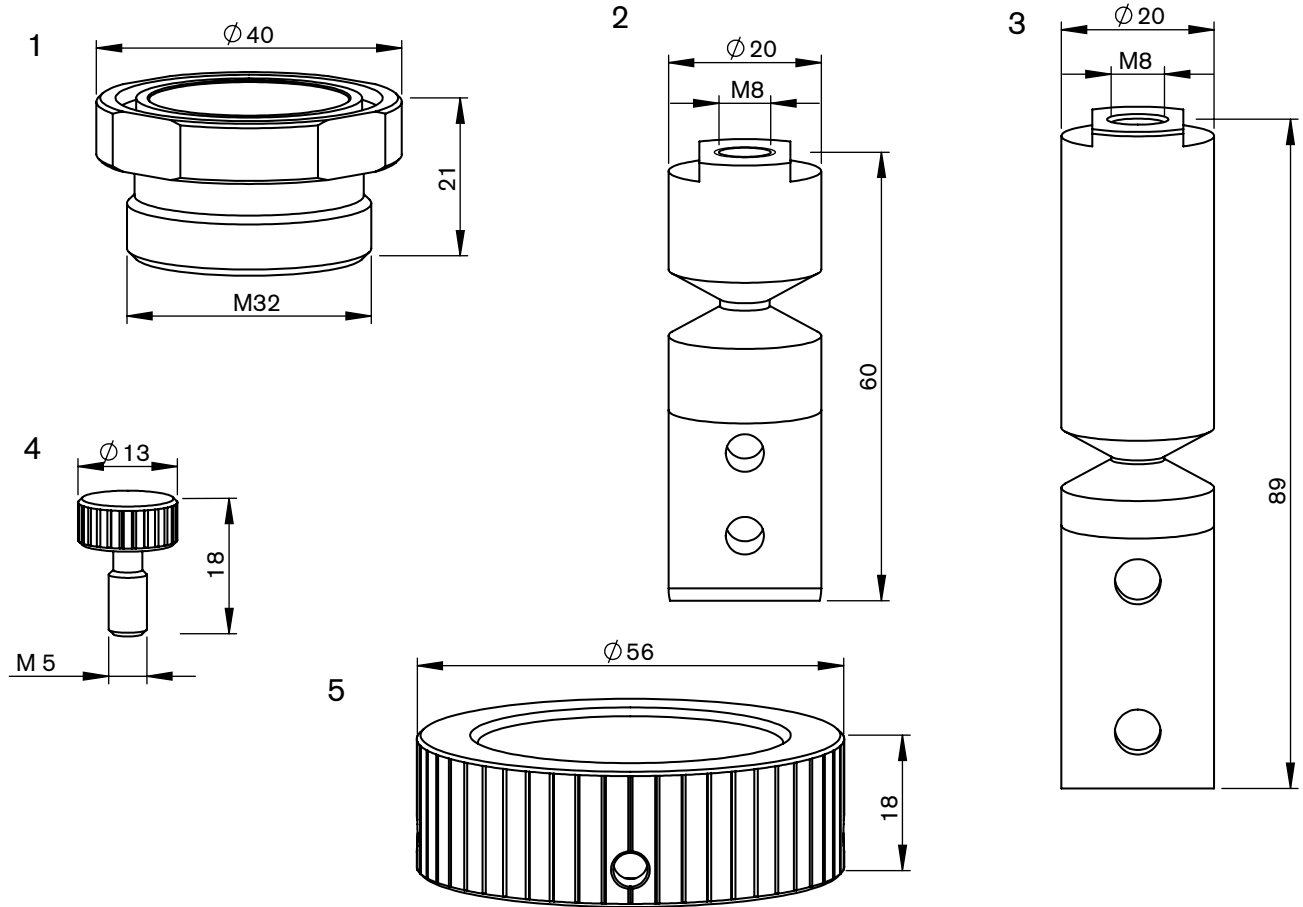

Consumables

	Centricut part number	Esse A part number	Reference number	Description	Pkg qty
1	MZ309-0080	AL63	46523300080	MZ-Base	1
	MZ309-3200 (not shown)	AL97		MZ-O-ring external base	1
2	MZ309-0280	AL14	36682300280, 36673300280	MZ-Breakaway bar L60-M8	1
3	MZ309-0550	AL12	36602300230	MZ-Breakaway bar L89-M8	1
4	MZ335-0320	AL152	46683300032, 46603300032	MZ-Bolt M5 x 0.5	1
5	MZ335-0930	AL153	46683300930	MZ-Ring	1

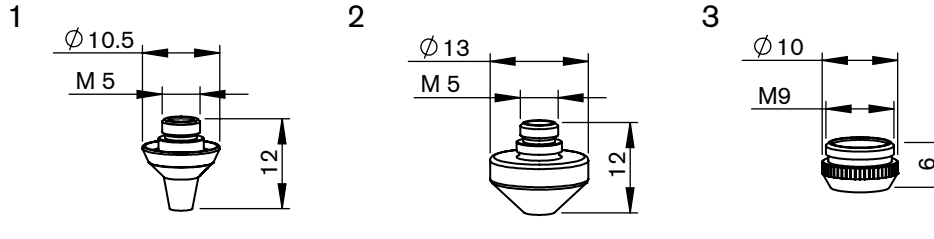

Consumables

	Centricut part number	Esse A part number	Reference number	Description	Pkg qty
1	PT347-0005X	L30554	46713300290-10	PT-Nozzle 3D, 1.0 mm (10 pk)*	10
	PT347-0290-1.2	L555	46713300290-12	PT-Nozzle 3D, 1.2 mm	1
	PT347-0090X	L30555	46713300290-12	PT-Nozzle 3D, 1.2 mm (10 pk)	10
	PT347-0290X	L30556	46713300290-15, P0352-381-00015	PT-Nozzle 3D, 1.5 mm (10 pk)*	10
	PT347-0118X	L30557	P0352-377-00018	PT-Nozzle 3D, 1.8 mm (10 pk)	10
	PT347-0280X	L30558	46713300310, P0352-382-00020	PT-Nozzle 3D, 2.0 mm (10 pk)*	10
	PT347-0001X	L30560	46713300280-25	PT-Nozzle 3D, 2.5 mm (10 pk)*	10
	PT347-0002X	L30563	46713300280-30, 46713300430	PT-Nozzle 3D, 3.0 mm (10 pk)*	10
	PT347-0035X	L30564	46713300280-35	PT-Nozzle 3D, 3.5 mm (10 pk)*	10
	PT347-0012X	L30577	46713300310	PT-Nozzle 2D, 1.2 mm (10 pk)	10
	PT347-0310X	L30578	P0352-386-00015	PT-Nozzle 2D, 1.5 mm (10 pk)*	10
	PT347-0300X	L30580	46713300300, P0352-387-00020	PT-Nozzle 2D, 2.0 mm (10 pk)*	10
	PT347-0003X	L30581	46713300300-25	PT-Nozzle 2D, 2.5 mm (10 pk)*	10
	PT347-0006X	L30582	46713300300-30	PT-Nozzle 2D, 3.0 mm (10 pk)*	10
3	PT347-0320	AL160	46713300321, P0352-311-00001	PT-Union Nut, Vespel	1

* Centricut parts available in single packs. To order single packs, remove the 'X' at the end of the part number (e.g. AM123-4567X would be AM123-4567). For Esse A parts available in single packs. To order single packs, remove the '30' after the L in the part number (e.g. L301401X would be L401X).

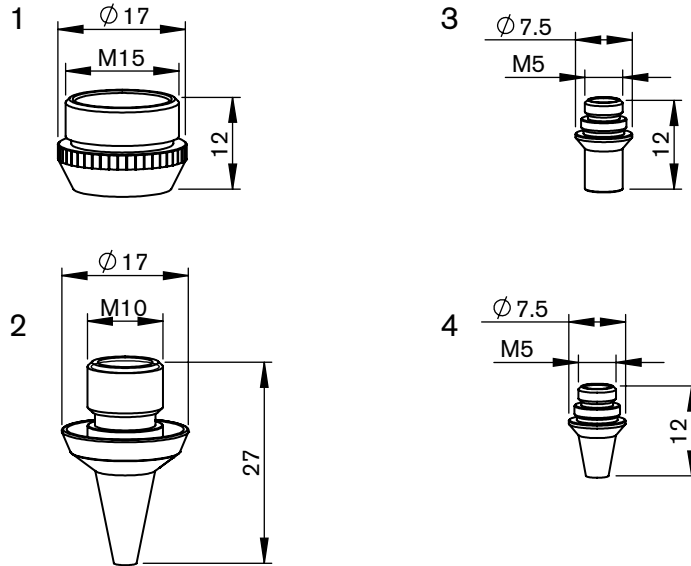

Consumables

	Centricut part number	Esse A part number	Reference number	Description	Pkg qty
1	MZ332-1280	AL337	46713331280	MZ-Nut, Vespel	1
2	MZ332-1320X	L301295	46713331320	MZ-Nozzle 3D, 1.2 mm (10 pk)*	10
	MZ332-1310X	L301296	46713331310	MZ-Nozzle 3D, 1.5 mm (10 pk)*	10
	MZ332-1301X	L301301		MZ-Nozzle 3D, 1.8 mm (10 pk)*	10
	MZ332-1300X	L301297	46713331300	MZ-Nozzle 3D, 2.0 mm (10 pk)*	10
	MZ332-1330X	L301298	46713331330	MZ-Nozzle 3D, 2.5 mm (10 pk)*	10
	MZ332-1290X	L301299	46713331290	MZ-Nozzle 3D, 3.0 mm (10 pk)*	10
3	PT347-1013X	L30482	281013, P0352-325-00015	PT-Nozzle ZK, 1.5 mm (10 pk)	10
	PT347-1025X	L30485	350044.3, P0352-328-00025	PT-Nozzle ZK, 2.5 mm (10 pk)*	10
4	PT347-1006X	L30486	281006, P0352-333-00010	PT-Nozzle KK, 1.0 mm (10 pk)	10
	PT347-1031X	L30488	281031, P0352-335-00015	PT-Nozzle KK, 1.5 mm (10 pk)*	10
	PT347-0898X	L30489	280898, P0352-336-00018	PT-Nozzle KK, 1.8 mm (10 pk)	10
	PT347-1020X	L30490	P0352-336-00020	PT-Nozzle KK, 2.0 mm (10 pk)*	10

* Centricut parts available in single packs. To order single packs, remove the 'X' at the end of the part number (e.g. AM123-4567X would be AM123-4567). For Esse A parts available in single packs. To order single packs, remove the '30' after the L in the part number (e.g. L301401X would be L401X).

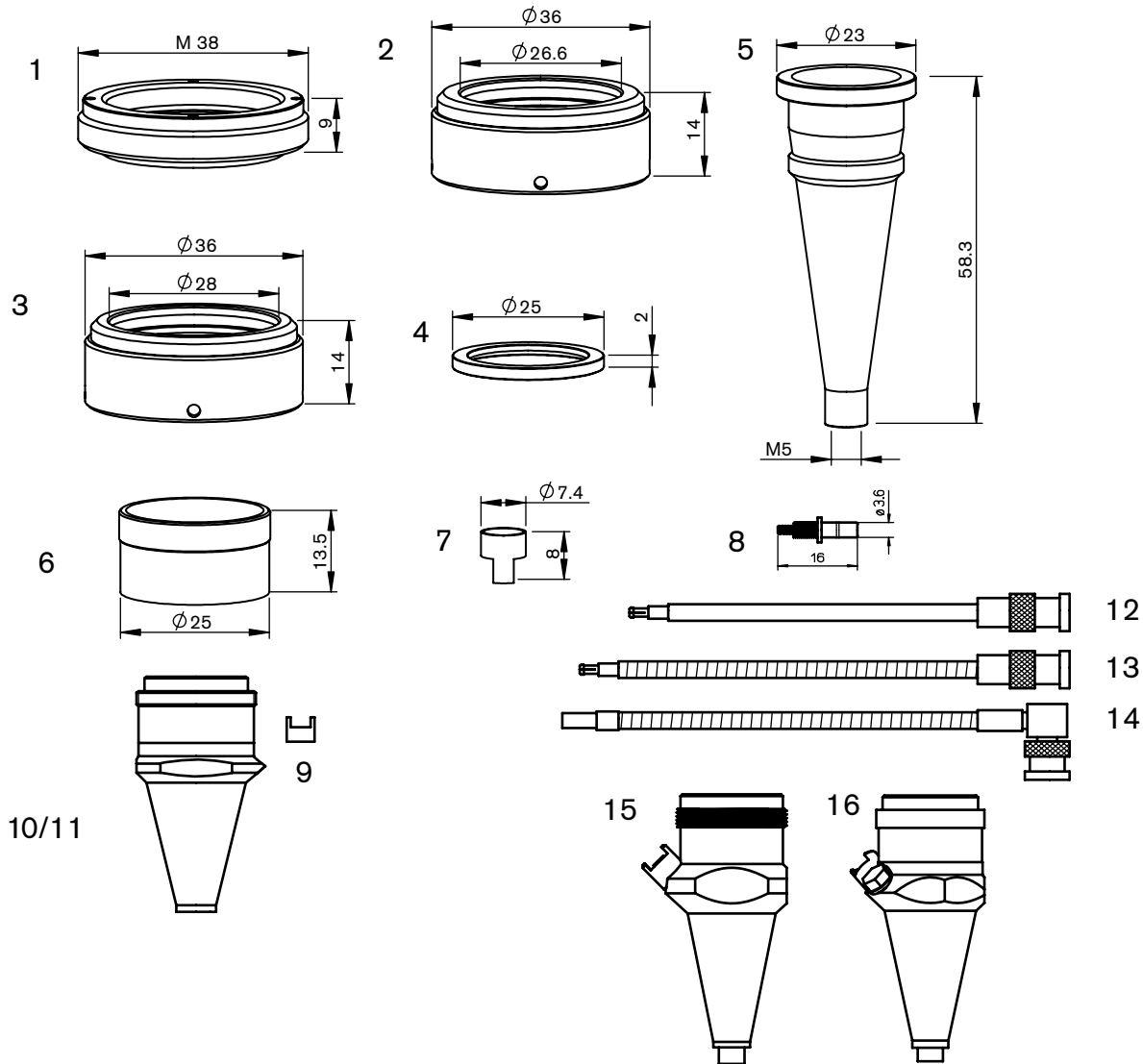

Consumables

	Centricut part number	Esse A part number	Reference number	Description	Pkg qty
1	PT347-4297	AL198	P0492-702-00001, 29100021	PT-Insulating ring outer body	1
	AM326-6453 (not shown)	AL94		AM-O-ring for outer nozzle	1
2	PT347-0008	AL218	46713330200	PT-Isolating ring outer body (Precitec)	1
3	PT347-0920	AL221	46713330920	PT-Isolating ring outer body (Mazak)	1
4	PT347-350	AL350	46713330960	PT-Isolating ring, inner cone	1
5	PT347-349	AL349	46713330930	PT-Sensor cone inner	1
6	PT347-0940	AL353	46713330940	PT-Retaining ring	1
7	PT347-0009	AL256	46713300390	PT-Connector protector	1
8	PT347-1111	AL354	46713331111	PT- Connector w/spring	1
9	PT347-9006	AL256		PT-Connector cup, HNP	1
10	PT347-1240	AL351	46713331240	PT-Torch outer body	1
11	PT347-0369	AL369		Complete outer torch (PT347-1240/1111/0009)	1
12	PT347-0101	AL204	P0360-100-00500, 46713300100	PT-Sensor head connecting cable OEM	1
13	PT347-1386	AL257	281386, P0360-155-00500	PT-Electrode cable	1
14	PT347-0181	AL358	46743300181	PT-Sensor cable	1
		AL364	46743300182	PT-Sensor cable 35CM	1
15	PT347-3323		567123323A1	PT-Sensor cone HNP	1
16	PT347-0007	AL211	P0354-110-00001	PT-Sensor cone HNZ	1

Centricut is not affiliated with the named manufacturers. Reference to machines, parts, descriptions, and model numbers are for convenience in verifying compatibility only. All parts are made by or for Centricut and are not made by the referenced manufacturers (unless expressly indicated). Centricut is a registered trademark of Hypertherm, Inc. All other trademarks are the properties of their respective owners.

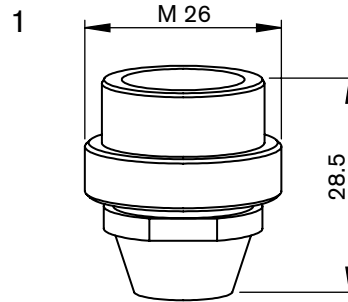

Consumables

	Centricut part number	Esse A part number	Reference number	Description	Pkg qty
1	MZ321-0510	AL11	46603350510	MZ-Nozzle adapter body	1

1



Consumables

	Centricut part number	Esse A part number	Reference number	Description	Pkg qty
1	MZ335-1330A		46683301330	MZ-Sensor cable, 305 mm (12") armored	1
	MZ335-1980A		46683301980, 46683301982	MZ-Sensor cable, 280 mm (11") armored	1
	MZ335-0111A (not shown)	AL620	46743300111	MZ-Sensor cable, 280 mm (11") armored	1
	MZ335-0181A (not shown)	AL621	46743300181	MZ-Sensor cable, 317.5 mm (12.5") armored	1
	MZ335-5320 (not shown)	AL105	46143355320	MZ-Sensor cable lower, 61.5 mm (2.42") armored	1
	MZ335-630A (not shown)	AL623		MZ-Sensor cable, 630 mm (25") armored	1
	MZ335-HNPS (not shown)	AL605	HNPS	MZ-Sensor cone, HNP short version	1

Consumables

	Centricut part number	Esse A part number	Reference number	Description	Pkg qty
	BY328-3884 (not shown)		333884	BY-Screws, plastic (2 pcs)	2
	AM313-2023 (not shown)		71232023, Z50MBP00090	AM-Vacuum pump filter	1

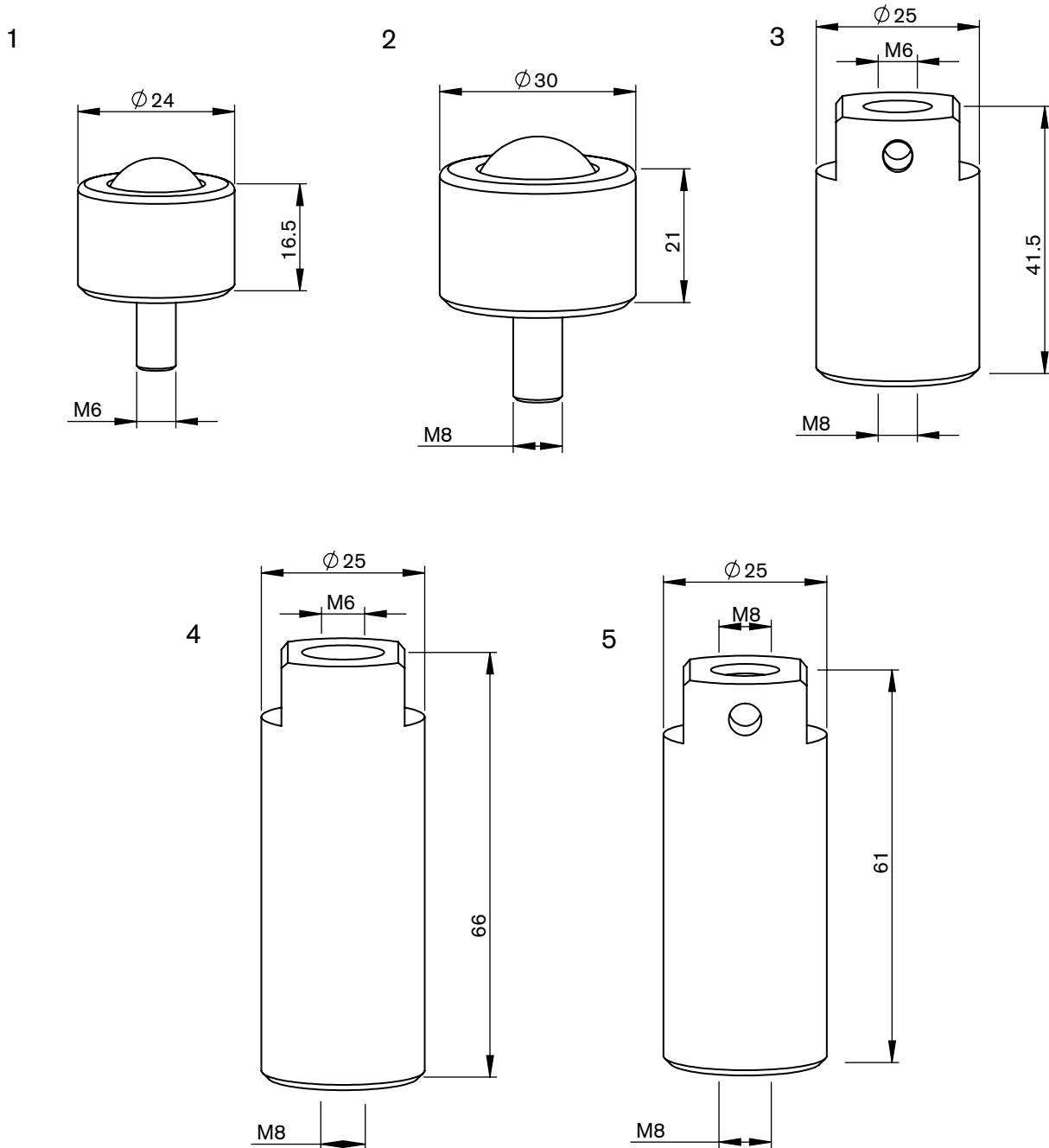

Consumables

	Centricut part number	Esse A part number	Reference number	Description	Pkg qty
1	MZ309-Z580	AL61	Z21KV000580	MZ-Roller ball M6, 25 mm	1
	MZ309-Z580X	AL3061	Z21KV000580	MZ-Roller ball M6, 25 mm (10 pk)	10
	MZ309-Z580B	AL325	Z21KV000580	MZ-Roller ball M6, 25 mm (2 pk)	1
2	MZ309-1160	AL210	Z21ZZ001160	MZ-Roller ball M8, 30 mm	1
3	MZ309-0321	AL62	46575100321	MZ-Block, L41.5 stainless steel	1
4	MZ309-0050	AL134	46705100050	MZ-Block, L66 stainless steel	1
5	MZ309-0324	AL324		MZ-Block, stainless steel	1

Centricut is not affiliated with the named manufacturers. Reference to machines, parts, descriptions, and model numbers are for convenience in verifying compatibility only. All parts are made by or for Centricut and are not made by the referenced manufacturers (unless expressly indicated). Centricut is a registered trademark of Hypertherm, Inc. All other trademarks are the properties of their respective owners.

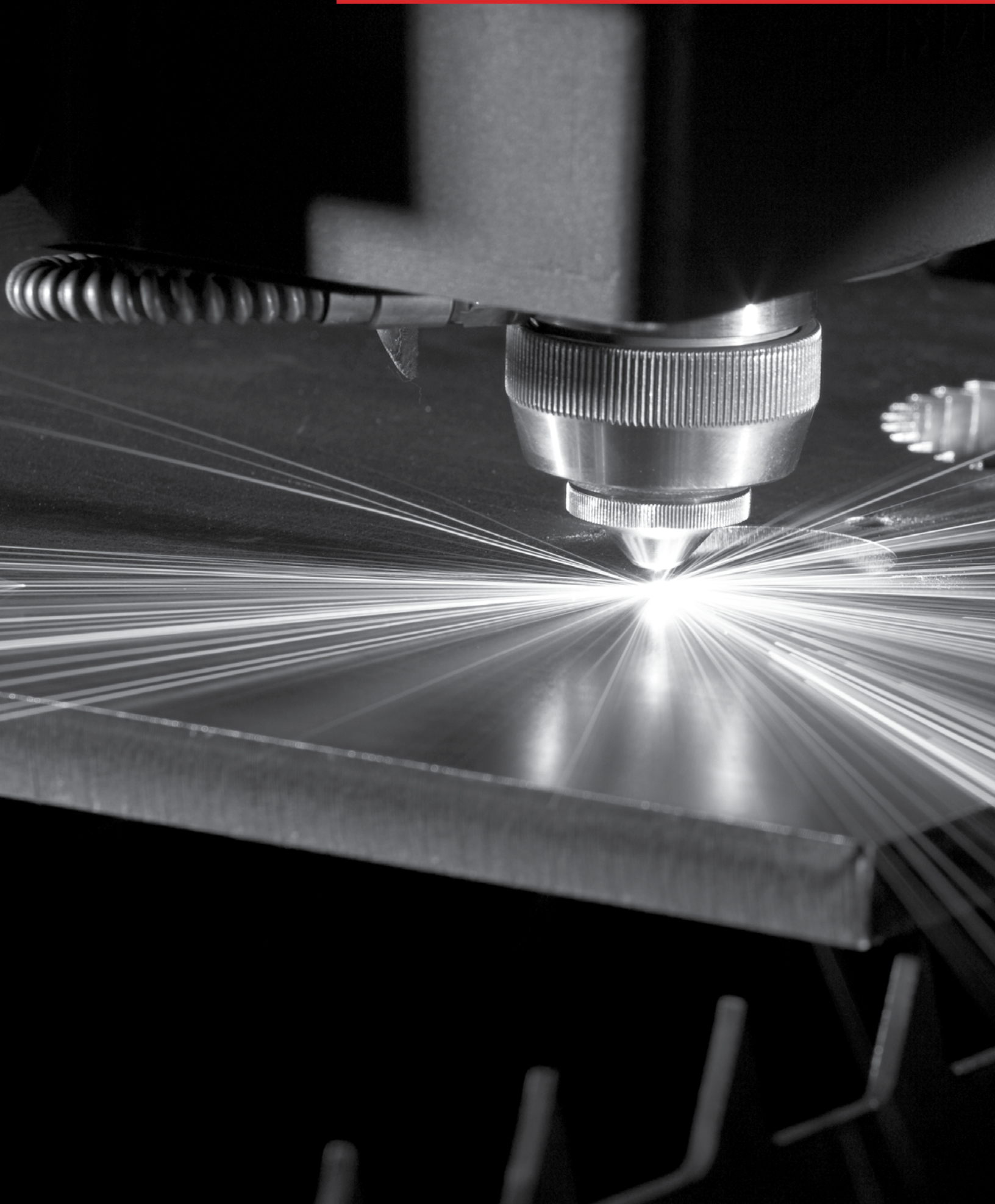

Sensor cones



Centricut sensor cones provide substantial cost savings without sacrificing performance or quality

- Available for Amada, Mazak, Mitsubishi and Precitec
- Delivers the same OEM performance at a lower cost
- Unmatched performance and reliability
- Engineered and manufactured to Hypertherm's precise quality standards
- Backed by our one-year warranty and 100% satisfaction guarantee

Centricut part number	Esse A part number	OEM	Reference number	Description
AM343-0091	AL600	Amada	71360091	AM-Sensor cone, HS95 mini
AM343-1621*	AL601	Amada	71341621	AM-Sensor cone, HS95
AM343-9107	AL603	Amada	ECO cone	AM-Sensor cone, ECO
AM343-1690	AL602	Amada	71341690	AM-Sensor cone, HS98
AM343-L3015C	AL550	Amada	71374509	PT-Sensor cone, LC3015
AM343-2443		Amada	7172443, 771041	AM-Sensor cone, HPL Blue
AM343-4233B*	AL551	Amada	71564233	AM-Sensor cone, HPL Black
AM343-4233G*	AL552	Amada	71564233	AM-Sensor cone, HPL Gold
PT347-3323	AL611	Mazak	HNP	PT-Sensor cone, HNP
MZ335-HNPS*	AL605	Mazak	HNPS	MZ-Sensor cone, HNP short version
PT347-0007		Mazak	56743300500	PT-Sensor cone, HNZ (Mazak)
PT347-0011*	AL607	Mitsubishi	P0354-110-00002	PT-Sensor cone, HNZ (Mitsubishi)
MB334-W429A	AL604	Mitsubishi	P0461-270-00001	MB-Sensor cone, W429A
PT347-0238*	AL608	Precitec	BQ930D238G01	PT-Sensor cone, HNZ SMA
PT347-8001	AL612	Precitec	P0361-203-00001	PT-Sensor cone, 2.5Z/J
PT347-0522*	AL609	Precitec	P0599-520-00002	PT-Sensor cone, LRC
PT347-1145	AL610	Precitec	P0380-140-0002, P0380-130-00001, 281145	PT-Sensor cone, DZ

*Sensor cone repair service is available for most sensor cones in North America and select international regions. For more information contact Ctlaser@Hypertherm.com.

Centricut is not affiliated with the named manufacturers. Reference to machines, parts, descriptions, and model numbers are for convenience in verifying compatibility only. All parts are made by or for Centricut and are not made by the referenced manufacturers (unless expressly indicated). Centricut is a registered trademark of Hypertherm, Inc. All other trademarks are the properties of their respective owners.

Armored sensor cables

Centricut armored sensor cables outlast standard OEM cables

- Available for all major brands
- Robust design with extreme temperature rating (900–1200°)
- Longer life reduces downtime and production loss
- Spatter resistant stainless steel armoring
- Reinforced collars and high-quality connector

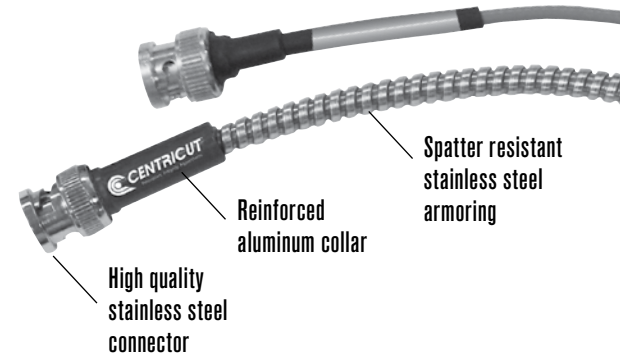

Armored sensor cables

Centricut part number	Esse A part number	OEM	Reference number	Description
AM308-8965	AL260	Amada	71398965	AM-Sensor cable, 305 mm (12")
AM308-8965A	AL613	Amada	71398965	AM-Sensor cable, 305 mm (12") armored
AM313-1901	AL200	Amada	71341630	AM-Sensor cable HS-5, 305 mm (12")
AM313-1901A		Amada	71341630	AM-Sensor cable HS-5, 305 mm (12") armored
AM313-8292	AL615	Amada	71398292	AM-Sensor cable dual shield, 7 m (275.6")
AM313-9851A		Amada	71369851	AM-Sensor cable, 203 mm (8") armored
CN306-0654A	AL616	Cincinnati	909654, 922686	CN-Sensor cable, 114 mm (4.5") armored
CN306-0951A	AL617	Cincinnati	842951	CN-Sensor cable, 140 mm (5.5") armored
CN306-2951	AL618	Cincinnati	842951, PLTTW0015	CN-Sensor cable, 140 mm (5.5")
CN306-9654	AL619	Cincinnati	909654, 922686, PLTTW0002	CN-Sensor cable, 114 mm (4.5")
MZ335-0111A	AL620	Mazak	4674330111	MZ-Sensor cable, 280 mm (11") armored
MZ335-0181A	AL621	Mazak	46743300181	MZ-Sensor cable, 317.5 mm (12.5") armored
MZ335-1330A	AL622	Mazak	46683301330	MZ-Sensor cable, 305 mm (12") armored
MZ335-1980A	AL643	Mazak	46683301980	MZ-Sensor cable, 280 mm (11") armored
MZ335-5320		Mazak	6143355320	MZ-Sensor cable, 61.5 mm (2.4") armored
MZ335-630A	AL623	Mazak	00BSBA630MNC	MZ-Sensor cable, 630 mm (25") armored
MZ335-8290	AL368	Mazak	46143308290	MZ-Sensor cable, 75 mm (3")
NT426-1682	AL624	NTC	4R029911-001, J482D	NT-Sensor cable, 216 mm (8.5")
NT426-4991	AL625	NTC	3-0104991	NT-Sensor cable 0-0BNC/MCX, 482 mm (19")
NT426-7492	AL626	NTC	3-0117492	NT-Sensor cable 90BNC/90BNC, 482 mm (19")
NT426-8677	AL627	NTC	4R028677-001	NT-Sensor cable, 508 mm (20") armored
PR361-3150	AL628	Prima	820.63.150	PR-Sensor cable, 150 mm (5.9")
PR361-3151	AL629	Prima	820.63.150	PR-Sensor cable, 150 mm (6") high profile
PR361-3160	AL560	Prima	555.63.150	PR-Sensor cable, 210 mm (8 17/64")
PT347-0101A	AL633	Precitec	P0360-100-00500	PT-Sensor cable, 500 mm (20") armored
PT347-0181	AL358	Precitec	46743300181	PT-Sensor cable, 305 mm (12") armored
PT347-0300A	AL635	Precitec	P0492-014-00300	PT-Sensor cable KE, 300 mm (11.8") armored
PT347-0450		Precitec	P0497-002-00450	PT-Sensor cable, 450 mm (17.7")
PT347-KS13	AL639	Precitec/ Gunkyo	00BMTKA-A-HS500mm	PT-Sensor cable, 390 mm (15.5") armored
PT347-1250	AL637	Precitec	D5001-040-00250	PT-Sensor cable, 250 mm (9.8") armored
TR301-0930	AL640	Trumpf	280930	TR-Sensor cable, 152 mm (6") armored
TR301-7833	AL641	Trumpf	227833	TR-Sensor cable, 432 mm (17")
TR301-9983	AL642	Trumpf	359983, 342474	TR-Sensor cable, 190 mm (7.5") armored

Centricut is not affiliated with the named manufacturers. Reference to machines, parts, descriptions, and model numbers are for convenience in verifying compatibility only. All parts are made by or for Centricut and are not made by the referenced manufacturers (unless expressly indicated). Centricut is a registered trademark of Hypertherm, Inc. All other trademarks are the properties of their respective owners.

Lens cleaning tips



Centricut supplies suitable for all OEM CO₂ and fiber laser lenses

- Lens maintenance base is designed to secure a wide range of optics sizes for the cleaning process
- Centricut optical cleaning fluid is a safe, economical alternative to traditional high-purity and reagent-grade solvents
- Cleaning materials suited for all lens cleaning needs; lens paper, polyester swabs and polyester wipes

Lens paper

Recommended for the routine maintenance cleaning of flat lenses.

Polyester swabs

Recommended for cleaning curved lenses and where a more aggressive cleaning is required (interchangeable with polyester wipes).

Polyester wipes

Recommended for cleaning CO₂ and fiber lenses and windows (interchangeable with polyester swabs and lens paper).

Product description	Part number	Quantity per order
Optical cleaning fluid (3 oz.)	TR300-1112	1
Lens cleaning swab	TR300-0699	25
Lens cleaning paper, Tiffen	TR300-6452	50
Polyester wipes 4" x 4"	TR300-7991	100
Base, lens maintenance	TR300-271	1

Lens paper

Recommended for the routine maintenance cleaning of flat lenses.

You will need:

- Lens maintenance base (lens holder)
- Optical cleaning fluid
- Air bulb
- Lint-free lens paper
- Latex or rubber gloves

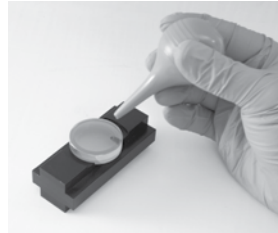

To get started

Using rubber gloves, place the lens in the lens holder and remove all loose contaminants with an air bulb. When contaminants are no longer visible, begin the cleaning process.

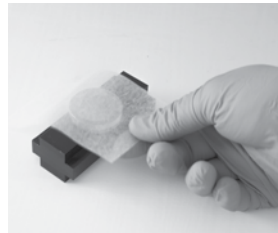

Step 1

Place lens paper over the optic, covering it completely.



Step 2

Apply a couple drops of lens cleaning fluid to the lens paper (far side of the lens).

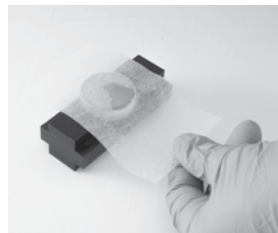

Step 3

Slowly pull the lens paper across the lens so the cleaning fluid comes in contact with the entire lens surface. Finish pulling the paper across so all of the fluid has dried from the lens.

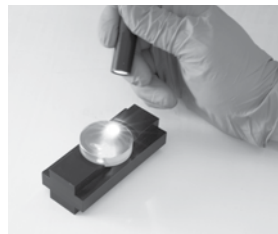

Step 4

Inspect the surface of the lens for dust and cleaning residue using a flashlight. Examine the lens from different angles. Repeat the process on the other side of the lens.

Final step:

Place the cleaned lens in the machine quickly to avoid contamination from airborne particles. If spots, pits, or scratches are still noticeable, the lens may need to be replaced.

Centricut is not affiliated with the named manufacturers. Reference to machines, parts, descriptions, and model numbers are for convenience in verifying compatibility only. All parts are made by or for Centricut and are not made by the referenced manufacturers (unless expressly indicated). Centricut is a registered trademark of Hypertherm, Inc. All other trademarks are the properties of their respective owners.

Polyester swabs

Recommended for cleaning curved lenses and where more aggressive cleaning is required. Interchangeable with polyester wipes.

You will need:

- Lens maintenance base (lens holder)
- Optical cleaning fluid
- Air bulb
- Polyester swabs
- Latex or rubber gloves

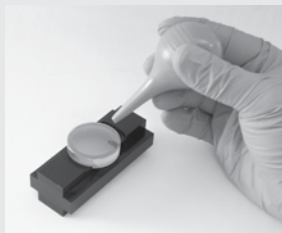

To get started

Using rubber gloves, place the lens in the lens holder and remove all loose contaminants with an air bulb. When contaminants are no longer visible, begin the cleaning process.



Step 1

Place a few drops of the optical cleaning fluid onto the swab.

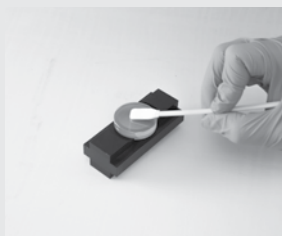

Step 2

Move the larger dirt particles and then finer contaminants to the edge of the lens using the swab. Do not rest the swab on the lens or on the work table. Do not reuse swabs.

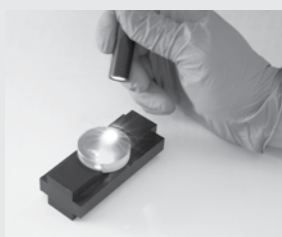

Step 3

Inspect the surface of the lens for dust and cleaning residue using a flashlight. Examine the lens from different angles. Repeat the process on the other side of the lens.

Final step:

Place the cleaned lens in the machine quickly to avoid contamination from airborne particles. If spots, pits, or scratches are still noticeable, the lens may need to be replaced.

Polyester wipes

Recommended for cleaning CO₂ and fiber lenses and windows. Interchangeable with polyester swabs and lens paper.

You will need:

- Lens maintenance base (lens holder)
- Optical cleaning fluid
- Air bulb
- Polyester wipes
- Latex or rubber gloves



To get started

Using rubber gloves, place the lens in the lens holder and remove all loose contaminants with an air bulb. When contaminants are no longer visible, begin the cleaning process.

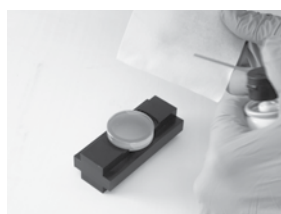

Step 1

Place a few drops of the optical cleaning fluid onto the polyester wipe.



Step 2

Place the wipe with the wet side down on the lens and slide it across the lens, applying light pressure to the top of the wipe. Avoid contamination to the wipe and do not reuse wipes.

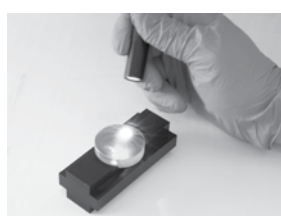

Step 3

Inspect the surface of the lens for dust and cleaning residue using a flashlight. Examine the lens from different angles. Repeat the process on the other side of the lens.

Final step:

Place the cleaned lens in the machine quickly to avoid contamination from airborne particles. If spots, pits, or scratches are still noticeable, the lens may need to be replaced.

Steps to help optimize cut quality.

Striation marks, angularity and dross tell the story.

Optimizing CO₂ and fiber lasers to achieve maximum cut quality is a very important step in the overall cutting process. The critical points that produce good cuts are the width of the kerf (the material that is lost during the cut), oxidation and roughness of the cut surface, the geometry of the cut parts and the allowable tolerances. Some factors to be considered are the cut speed or 'feed rate', beam focus, gas pressure, standoff and nozzle size/type.

Factory cut chart settings

The following samples show 12 mm, 6 mm and 3.2 mm (1/2", 1/4" and 10 ga.) mild steel, cut with O₂ on a 2 kW fiber laser with one variable changed to show how cut quality is affected. The adjustments will be similar for all CO₂ and fiber laser, cutting mild steel with O₂.

Is the kerf too narrow?

When the kerf is too narrow the cut will have a very smooth edge on the top, a lack of oxidation on the bottom and/or heavy dross.

Probable causes:

- Focus is too low
- Feed rate is too fast
- Gas pressure is too low
- Nozzle size is too small
- Standoff is too low

Follow these steps to optimize cut quality:

1. Use the closest known settings for the material being cut.
2. Use a test part that has both interior and exterior features.
3. Verify that the lens and/or window is clean and in good condition.
4. Verify that the nozzle is centered properly and is in good condition.
5. Adjust the focus up and down until the cut quality starts to get bad and then set to the middle of that range.
6. Adjust the gas pressure up and down until the cut starts to get bad and then set to the middle of that range.
7. Adjust the federate up by 5% increments. When the cut starts to get bad, set the feed rate 10% slower.

Strike a balance between heat levels and gas flow

Cutting mild steel with a laser is a balance of how much material is heated by the laser beam and how much assist gas flows through the cut.

- Heating up too small of an area, or not having enough assist gas flow through the cut will result with the kerf (width of the cut) being too narrow.
- Heating up too large of an area or having too much assist gas flow through the cut will result in the kerf being too wide.

Is the kerf too wide?

When the kerf is too wide the cut will have a rougher edge, more self burning in the corners of the part, more angularity on the cut edge and occasionally, dross.

Probable causes:

- Focus is too high
- Feed rate is too slow
- Gas pressure is too high
- Nozzle size is too big
- Standoff is too high
- Incorrect nozzle type

3.2 mm (10 ga.) mild steel cut resulting in too narrow kerf

Factory cut chart settings



Focus is too low

The kerf is too narrow and doesn't allow enough O₂ into the cut to remove all the molten material.

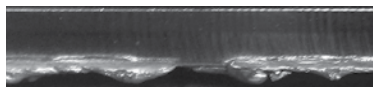

Feed rate is too fast

The cut striations are trailing the direction of cutting and there is not enough time to remove all the molten material.

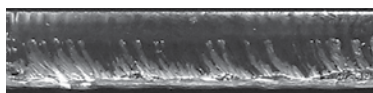

Gas pressure is too low

There is not enough O₂ to remove all the molten material.

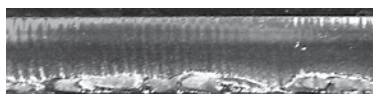

Stand off is too low

The focus spot is in the wrong location, causing the rough edge.

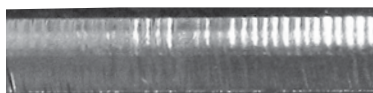

3.2 mm (10 ga.) mild steel cut resulting in too wide kerf

Factory cut chart settings



Focus is too high

The laser is melting more material than can be removed from the cut.

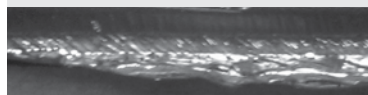

Feed rate is too slow

The cut surface is too rough and productivity is decreased.

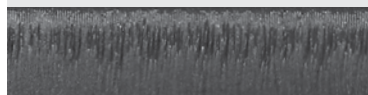

Gas pressure is too high

Too much O₂ results in overheating of the cut and causes intermittent gouges.



Stand off is too high

The laser is melting more material than can be removed from the cut.

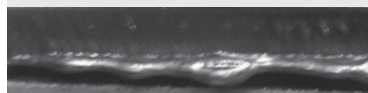

Nozzle size is too big

Too much O₂ results in overheating of the cut and causes intermittent gouges.



*Above samples have been cut with O₂ on 2 kW fiber laser. Results will be similar for CO₂ laser cutting mild steel with O₂.

6 mm (1/4") mild steel cut resulting in too narrow kerf

Factory cut chart settings

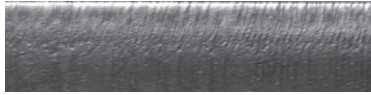

Focus is too low

The kerf is too narrow and doesn't allow enough O₂ into the cut to remove all the molten material.

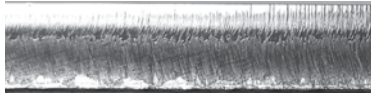

Feed rate is too fast

The cut striations are trailing the direction of cutting and there is not enough time to remove all the molten material.

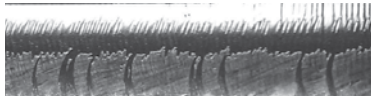

Gas pressure is too low

There is not enough O₂ to remove all the molten material.

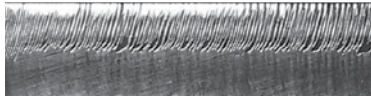

Stand off is too low

The focus spot is in the wrong location, causing the rough edge.

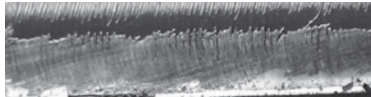

Nozzle size is too small

There is not enough O₂ to cut uniformly.

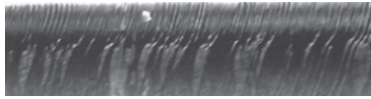

Cut direction

6 mm (1/4") mild steel cut resulting in too wide kerf

Factory cut chart settings

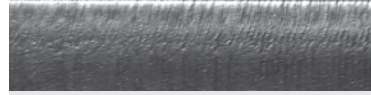

Focus is too high

The wider focus spot is letting too much O₂ into the cut and burning the material.

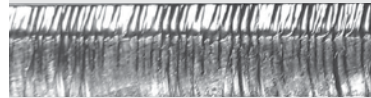

Feed rate is too slow

The cut surface is too rough and productivity is decreased.

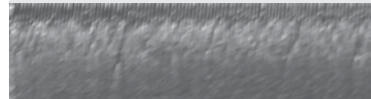

Gas pressure is too high

Too much O₂ is entering the cut, causing a rougher edge and inconsistent cutting.



Stand off is too high

Too much O₂ is entering the cut, causing a rougher edge and inconsistent cutting.

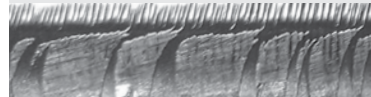

Nozzle size is too big

Too much O₂ results in overheating of the cut and causes intermittent gouges.



Nozzle type is incorrect

The shape of the gas flow is incorrect, causing a rougher edge.



Cut direction

*Above samples have been cut with O₂ on 2 kW fiber laser. Results will be similar for CO₂ laser cutting mild steel with O₂.

Centricut is not affiliated with the named manufacturers. Reference to machines, parts, descriptions, and model numbers are for convenience in verifying compatibility only. All parts are made by or for Centricut and are not made by the referenced manufacturers (unless expressly indicated). Centricut is a registered trademark of Hypertherm, Inc. All other trademarks are the properties of their respective owners.

12 mm (1/2") mild steel cut resulting in too narrow kerf

Factory cut chart settings

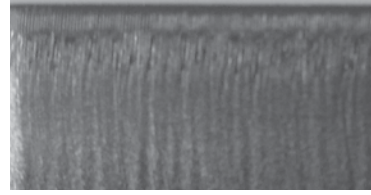
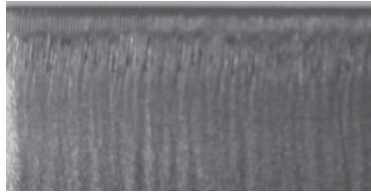

Factory cut chart settings

Focus is too low

The kerf is too narrow and doesn't allow enough O₂ into the cut to remove all the molten material.

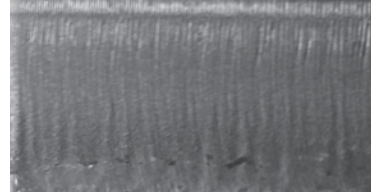
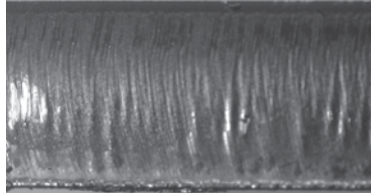

Stand off is too low

The kerf is too narrow to allow enough O₂ into the cut. The oxidation is not covering the entire surface and cutting will be inconsistent.

Feed rate is too fast

The machine is moving too fast to allow enough O₂ into the cut for consistent cutting.

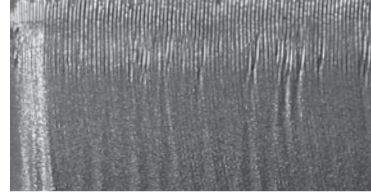
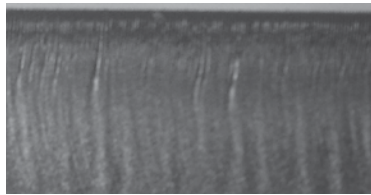

Nozzle size is too small

There is not enough O₂ to cut uniformly.

Gas pressure is too low

The pressure is too low to allow enough O₂ into the cut. The oxidation is not covering the entire surface and cutting will be inconsistent.

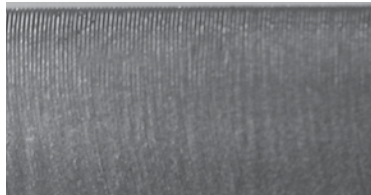

Cut direction

Cut direction

*Above samples have been cut with O₂ on 2 kW fiber laser. Results will be similar for CO₂ laser cutting mild steel with O₂.

Centricut is not affiliated with the named manufacturers. Reference to machines, parts, descriptions, and model numbers are for convenience in verifying compatibility only. All parts are made by or for Centricut and are not made by the referenced manufacturers (unless expressly indicated). Centricut is a registered trademark of Hypertherm, Inc. All other trademarks are the properties of their respective owners.

12 mm (1/2") mild steel cut resulting in too wide kerf

Factory cut chart settings

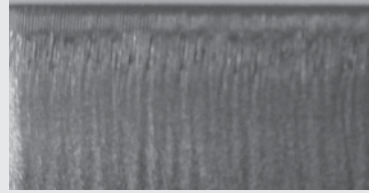
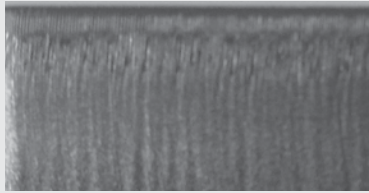

Factory cut chart settings

Focus is too high

Too much O₂ is entering the cut causing intermittent over burning.

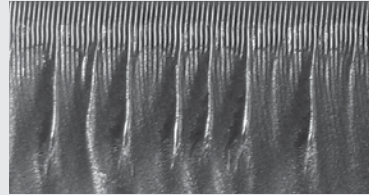
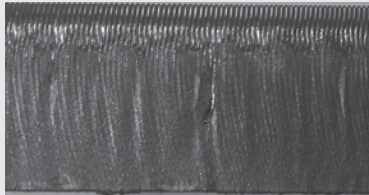

Stand off is too high

Too much O₂ is entering the cut resulting in intermittent over burning.

Feed rate is too slow

The machine is moving too slow resulting in the over burning of the bottom half of the cut. The slower feed rate also reduces productivity.

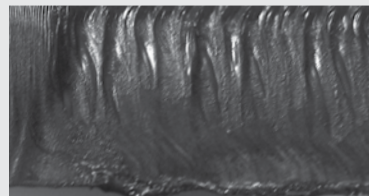
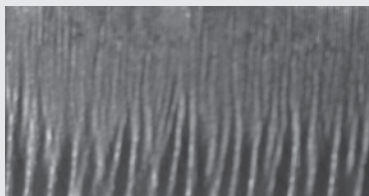

Incorrect nozzle type

The gas flow shape is not correct resulting in inconsistent cutting.

Gas pressure is too high

Too much O₂ is entering the cut resulting in intermittent over burning.

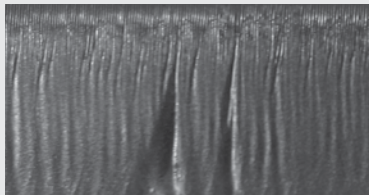

*Above samples have been cut with O₂ on 2 kW fiber laser. Results will be similar for CO₂ laser cutting mild steel with O₂.

Centricut is not affiliated with the named manufacturers. Reference to machines, parts, descriptions, and model numbers are for convenience in verifying compatibility only. All parts are made by or for Centricut and are not made by the referenced manufacturers (unless expressly indicated). Centricut is a registered trademark of Hypertherm, Inc. All other trademarks are the properties of their respective owners.

Technical support and customer service

Our technical service team can answer questions about any laser cutting system. Whether it's a question about a part, a system or for guidance on how to optimize laser cutting performance, our experts can help.

- OEM trained technicians with over 40 years experience
- Free application support for all laser OEMs
- We stand behind our products with industry-leading technical expertise

A photograph showing three men in a factory environment. They are gathered around a large industrial control panel for a laser cutting machine. The man on the left is wearing safety glasses and a light blue shirt, looking at the panel. The man in the middle is also wearing safety glasses and a light blue shirt, looking towards the right. The man on the right is wearing safety glasses and a dark shirt, looking at the panel. The control panel has a large screen displaying a software interface, several buttons, and a prominent red emergency stop button. The background is slightly blurred, showing industrial equipment.

Contact a laser expert at ctlaser@hypertherm.com

SHAPING POSSIBILITY[®]

PLASMA | LASER | WATERJET | AUTOMATION | SOFTWARE | CONSUMABLES

For more information on Centricut laser products,
visit www.hypertherm.com/laserconsumables
or email ctlaser@hypertherm.com

Hypertherm, Centricut, SilverLine and CoolFlow are trademarks of Hypertherm, Inc., and may be registered in the United States and/or other countries. All other trademarks are the property of their respective owners.

Please visit www.hypertherm.com/patents for more details about Hypertherm Associates patent numbers and types.

© 1/2024 Hypertherm, Inc. Revision 12



As 100% Associate owners, we are all focused on delivering a superior customer experience.
www.hyperthermassociates.com/ownership

Environmental stewardship is one of Hypertherm Associates' core values. www.hyperthermassociates.com/environment

100% Associate-owned

